

ISUZU

SPECIFICATIONS

FTR 150-260

FTR 150-260 CREW

Now with
Sat Nav fitted
as standard*



FTR 150-260 Crew



FTR 150-260

Image for illustrative purposes only.

* Satellite Navigation functions and maps provided at no extra cost, with up to four quarterly updates provided by user free download for the first three years of ownership, after which updates can be purchased at additional cost.

AUSTRALIA'S TOP SELLING TRUCK BRAND SINCE 1989.

AT A GLANCE*

GVM	15,000 kg
GCM	24,000 kg (manual model) 20,500 kg (auto model)
Power	191 kW @ 2,400 rpm
Torque	761 Nm @ 1,450 - 2,400 rpm

* Refer to back page for detailed weight rating information

ADVANCED TECHNOLOGY

Emissions: Euro V / ADR 80/03	Electro-hydraulic cab tilt
Driver and passenger airbag with seatbelt pretensioner	Coil spring cab suspension - except crew
ADR42 compliant sleeper with mattress - except crew	Front and rear stabiliser bars
ECE-R29 compliant cab	Cruise control
Anti-lock Braking System (ABS)	Isri 6860 seat with integrated seatbelt
Hill Start Aid (HSA) - except auto model	Isri 6860 front passenger seat with integrated seatbelt - crew model only
Electric mirrors	Cornering lamps



ISUZU TRUCKS

DRIVELINE AND CHASSIS SPECIFICATIONS

ISUZU 6HK1-TCC

- Type:** 6 cylinder 24 valve SOHC
- Displacement:** 7,790 cc
- Compression Ratio:** 17.5:1
- Bore x Stroke:** 115 mm x 125 mm
- Max power (DIN-NET):** 191 kW (256 HP) @ 2,400 RPM
(JIS Gross): 198 kW (265 HP) @ 2,400 RPM
- Max torque (DIN-NET):** 761 Nm (561 lb.ft) @ 1,450 - 2,400 RPM
(JIS Gross): 788 Nm (581 lb.ft) @ 1,450 - 2,400 RPM
- Induction system:** Electronically controlled variable nozzle turbocharger with air-to-air intercooler.
- Fuel injection:** Direct injection high pressure common rail system.
- Emission control system:** Cooled EGR with exhaust Diesel Particulate Diffuser (DPD). ADR 80/03 (Euro V) compliant. EEV compliant.

CLUTCH (MANUAL TRANSMISSION MODEL)

- Air assisted hydraulic control. Single plate 381 mm diameter.
- Total lining area: 1,363 cm²

TRANSMISSION

ISUZU MZW-6P (except auto model)

- 6 speed manual with air assisted shift.
 - Synchromesh on gears 2-6. Triple cone synchromesh on 2nd and 3rd gears. Integral oil pump provides full pressure lubrication.
 - PTO provision on LHS of transmission case. PTO drive from mainshaft gear.
 - Gear ratios (:1)
- | 1st | 2nd | 3rd | 4th | 5th | 6th | Rev |
|-------|-------|-------|-------|-------|-------|-------|
| 6.615 | 4.095 | 2.358 | 1.531 | 1.000 | 0.722 | 6.615 |

ALLISON LCT2500 (auto model)

- 6 speed automatic. 5th generation electronic controls with adaptive shift.
 - Allison long life TranSynd synthetic fluid.
 - LHS and RHS PTO openings on transmission case. Torque convertor turbine driven PTO drive gear.
 - Gear ratios (:1)
- | 1st | 2nd | 3rd | 4th | 5th | 6th | Rev |
|------|------|------|------|------|------|------|
| 3.51 | 1.90 | 1.44 | 1.00 | 0.74 | 0.64 | 5.09 |

AXLES

- Front:** Isuzu F063
- Reverse Elliot I-Beam. 6,300 kg capacity.
- Rear:** Isuzu R092
- Full floating Banjo type. 9,200 kg capacity.
 - Drive ratio: 5.571:1 (manual model), 6.143 (auto model)

SUSPENSION

- Front:**
- Single stage alloy steel taper-leaf springs.
 - Double acting hydraulic shock absorbers. Stabiliser bar.
- Rear:**
- Multi leaf main spring, multi leaf helper spring. Stabiliser bar.

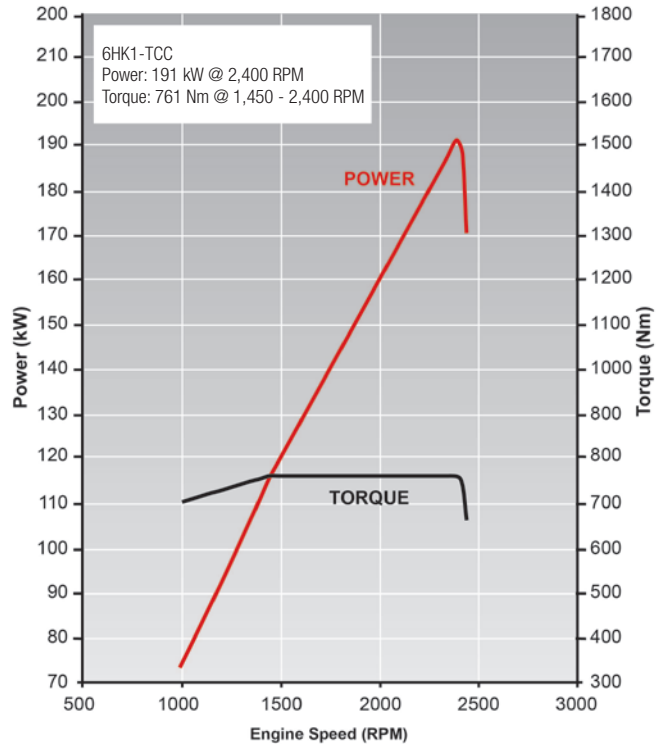

BRAKES

- Dual circuit full air taper roller front and rear drum brakes.
- ABS.
- Hill Start Aid (HSA) - except auto model.
- Front drum size: 410 x 160 mm
- Rear drum size: 410 x 180 mm
- Spring park brake.
- Air controlled exhaust brake.
- Air dryer.

STEERING

- Power assisted recirculating ball steering.
- Gear ratio: 22.4:1
- Turns lock to lock: 4.8
- Maximum angle: 49° (inside wheel) / 37° (outside wheel)

WHEELS AND TYRES

- 22.5 x 8.25 ten stud steel wheels.
- 275/70R22.5 148/145M Michelin X Multi Z Tubeless.
- Maximum tyre rating:
 - Steer axle: 6,300 kg
 - Drive axle: 11,600 kg
- Spare wheel and tyre assembly with winch type carrier.

CHASSIS FRAME

- Cold rivetted ladder frame with parallel side rails. HT540A high tensile weldable steel sidemembers.
- Frame dimensions:
 - Side rail (mm): 254 x 85 x 8.0
 - Rear frame width (mm): 850

FUEL TANK

- Frame mounted 200L steel fuel tank.
- Lockable fuel cap.

ELECTRICAL SYSTEM

- 24 volt electrical system.
- 90 amp alternator.
- 24 volt, 5.0 kW starter motor.
- 2 x 115E41L (651 CCA) batteries connected in series.
- Underdash CAN interface unit and connector. SAE J1939 protocol. Facilitates connection to a Fleet Management System (FMS) (not supplied).

CABIN SPECIFICATIONS AND APPOINTMENTS

CAB EXTERIOR

- All steel construction with electro-hydraulic cab tilt. High tensile steel used for cab underframe.
- Complies with ECE-R29 cab strength standard.
- **Single cab:** Full floating cab with coil spring suspension.
- **Crew cab:** Rubber cab mounts.
- Heavy duty non slip entry steps.
- 90° opening internally reinforced front doors.
- Water spray suppression guards and front mudflaps.
- Laminated windscreen with shade band.
- Two speed windscreen wipers with intermittent wipe mode.
- Halogen multi-reflector headlamps incorporating turn signals and front foglamps. Additional door mounted side indicator lamps.
- Combination brake, turn, reverse and marker lamps, registration plate illumination lamps. Extended wiring harness. Reverse alarm.
- Roof-mounted clearance lamps.
- Heated and powered exterior main mirrors with flat glass and additional powered convex "spot" mirrors.
- Body coloured grille.
- Body coloured steel air dam bumper with side cornering lamps.
- FUPD underbar - complies with ECE R93.

CAB INTERIOR

- Isri 6860 air suspension driver's seat with pneumatic lumbar support, height, rake and automatic weight adjustment.
- **Single cab:** Front passenger adjustable bucket seat.
- **Crew cab:** Isri 6860 air suspension front passenger seat with pneumatic lumbar support, height, rake and automatic weight adjustment.
- Front centre seat with folding seat back.
- **Crew cab:** Rear bench seat with 4 seat capacity.
- 3-point lap sash seatbelts in all outboard seating positions. Driver seatbelt with pre-tensioner integrated with driver seat. Outboard front passenger seatbelt fitted with pre-tensioner. Centre seat lap belts. **Crew cab:** Outboard front passenger seatbelt integrated with seat.
- **Single cab:** ADR42 compliant sleeper with mattress.
- Driver and outboard front passenger airbag.
- Door and roof pillar entry assist grips. **Crew cab:** Full width rear grab rail with ashtray.
- Full interior trim, padded roof lining and vinyl floor covering. Driver and passenger windscreen header storage shelf.
- Tilt/Telescopic adjustable steering column, soft feel urethane steering wheel.
- Electric windows.
- Central locking with remote keyless entry and immobiliser.
- Twin cup holders. 24V cigarette lighter. Dashboard hook.
- Front door mounted storage pockets and driver's side ashtray.
- Centre console box with storage tray. Fold down storage tray behind centre seat backrest.
- Fully integrated air conditioning and heater/demister with 4-speed fan and outlets for windscreen, side windows, face and floor.
- Fluorescent type interior lamp with On/Door/Off switch.

- 2 DIN, two speaker multimedia unit with 6.2" LCD capacitive touch screen. 1.6GHz processor with Android operating system. DAB+ digital radio and fully integrated Bluetooth with voice recognition. Inbuilt PDF, photo and movie viewer. Internet radio accessible via smartphone. 32GB internal file storage. USB and auxilliary input connection provisions. Firmware and map updates possible via smartphone.
- DIN sized compartment for storage or for CB radio installation.

ISUZU SATELLITE NAVIGATION

Integrated with radio/CD multimedia unit. Displayed information includes:

- Points of interest and Isuzu truck dealer locations.
- Road safety alerts.
- Speed limits and traffic signals.
- Route selection based on entered information such as vehicle weight and dimensions.

DRIVER CONTROLS

- Key-operated engine start/stop and steering lock. Engine idle speed control.
- HSA slow/fast engagement control and on/off switch - except auto model.
- DPD regeneration.
- T-bar gear selection control (auto model).
- **Left side combination stalk:** Windscreen wipers, washers and exhaust brake.
- **Right side combination stalk:** Turn signals, headlamps and cruise control.

INSTRUMENTATION

- Electronically driven speedometer and tachometer. Digital odometer with integrated dual tripmeter. Engine coolant temperature, fuel level and air pressure gauges.
- **Warning lamps:** Check engine, oil pressure, low coolant level, ABS, SRS airbag, alternator charge, service brakes, park brake, seat belt unfastened, low air pressure, low fuel level, cab lock.
- **Indicator lamps:** HSA (except auto model), warm up system, high beam, DPD status, exhaust brake, turn signals, cruise control.
- Multi information display. Shows service intervals, vehicle systems status, instantaneous and average fuel consumption, DPD bar chart, hourmeter, voltmeter, time/day/date and includes 40-120km/h adjustable vehicle speed warning.

OPTIONS AND GENUINE ACCESSORIES

Include the following (extra cost, request a brochure and further details from your Isuzu dealer):

Multimedia unit:

- Supports up to five camera inputs. One digital camera with infra red and rear microphone input active when reversing. Four analogue cameras.
- Reversing sensors
- Tyre pressure monitoring system

Other:

- Airbag compatible bullbar.
- Air deflector.

ISUZU CARE

Isuzu Care gives truck owners access to products and services including Roadside Assist, Service Agreements, Extended Care, Extended Isuzu Assist and the Isuzu Care Centre. Call 1800 035 640.

WEIGHTS (kg)

Models	Ratings*		Loading Limit* (at ground)		Cab Chassis Mass #		
	GVM	GCM	Front	Rear	Front	Rear	Total
FTR 150-260 MWB	15,000	24,000**	6,300	9,200	3,130	1,705	4,835
FTR 150-260 AUTO MWB	15,000	20,500**	6,300	9,200	3,130	1,700	4,830
FTR 150-260 MLWB	15,000	24,000**	6,300	9,200	3,290	1,740	5,030
FTR 150-260 AUTO MLWB	15,000	20,500**	6,300	9,200	3,295	1,750	5,045
FTR 150-260 LWB	15,000	24,000**	6,300	9,200	3,325	1,780	5,105
FTR 150-260 AUTO LWB	15,000	20,500**	6,300	9,200	3,330	1,800	5,130
FTR 150-260 CREW	15,000	24,000**	6,300	9,200	3,395	1,875	5,270
FTR 150-260 AUTO CREW	15,000	20,500**	6,300	9,200	3,400	1,875	5,295

* Vehicle ratings and front/rear weight limits are subject to government regulatory requirements and weight distribution analysis. Consult your Isuzu dealer to select the correct vehicle for your specific application. ** For tow couplings with a rating over 4,500kg brake performance matching with trailer is required to ensure compatibility under ADR 35/04. Auto models: Pre-approved ratings as stated apply for general transport and distribution applications. For other applications approval from Allison is required. # Cab chassis only as supplied and including 10 litres of fuel.

DIMENSIONS (mm)

Models	WB	OAL	FOH	ROH	EA	CE	RT	ORT	CH	FFA (unladen)	RFA (unladen)	RFH (unladen)	Turn Circle (m)
													KERB TO KERB
FTR 150-260 MWB	4,250	7,405	1,440	1,715	3,550	5,340	1,820	2,430	2,810	945	1,025	1,050	14.1
FTR 150-260 MLWB	6,050	10,005	1,440	2,515	5,350	7,940	1,820	2,430	2,810	945	1,015	1,050	20.1
FTR 150-260 LWB	6,500	10,740	1,440	2,800	5,800	8,675	1,820	2,430	2,810	935	1,010	1,040	21.6
FTR 150-260 CREW	6,050	10,005	1,440	2,515	4,625	7,248	1,820	2,430	2,875	935	1,015	1,055	20.1

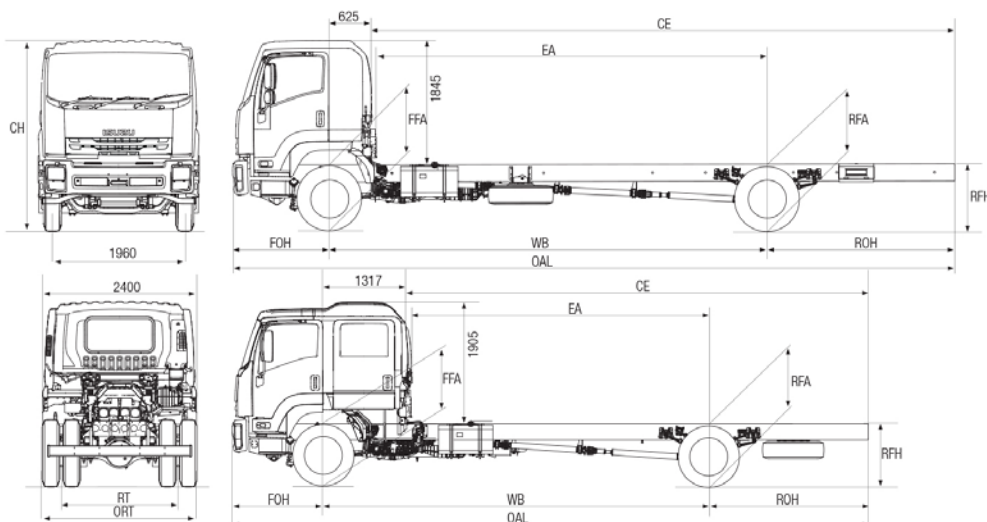

PERFORMANCE (calculated - typical paved road)

		Geared Speed* (top gear at peak power engine RPM)	Low Speed Gradeability (lowest forward gear assuming no wheel slip)	Engine Speed (top gear at 100km/h)
FTR 150-260	At 15,000kg GVM	106 km/h @ 2,400 RPM	36%	2,275 RPM
FTR 150-260 AUTO	At 15,000kg GVM	108 km/h @ 2,400 RPM	33%	2,220 RPM

*Maximum speed achievable depends on vehicle frontal area as well as other factors. Consult your Isuzu dealer for more detailed information. Vehicle is speed limited to 100km/h.

ISUZU WARRANTIES

STANDARD ¹	
New Vehicle	3 years • 150,000km • 2,500 hours
Cab Perforation Corrosion	3 years • unlimited km
Isuzu Assist: 24 hour roadside assistance (3 years, unlimited km)*	
EXTENDED CARE ²	
Extended Warranty: 5 years • 300,000km • 5,000 hours	
Isuzu Assist: 24 hour roadside assistance (5 years, unlimited km)	

ORDER CODES

Model	Code	Model	Code
FTR 150-260 MWB	FH-FTRJG-B18 (LM81)	FTR 150-260 CREW	FH-FTRLG-D18 (LM81)
FTR 150-260 AUTO MWB	FH-FTRJF-L18 (LM81)	FTR 150-260 AUTO CREW	FH-FTRLF-N18 (LM81)
FTR 150-260 MLWB	FH-FTRJG-C18 (LM81)		
FTR 150-260 AUTO MLWB	FH-FTRJF-M18 (LM81)		
FTR 150-260 LWB	FH-FTRJG-D18 (LM81)		
FTR 150-260 AUTO LWB	FH-FTRJF-N18 (LM81)		

¹ Subject to the conditions outlined in the IAL New Vehicle Warranty, the Isuzu FTR models carry a standard factory warranty which covers the owner: (i) for the entire vehicle, for the first 36 months or 150,000 km or 2,500 hrs (whichever comes first), (ii) against cab perforation corrosion, for 36 months and unlimited kilometres. ² Extended Warranty as illustrated may be purchased to cover the owner against the failure of original components, but may exclude some components and expendable items such as oil, filters, etc. *Valid for three years from the date of new vehicle purchases. All Isuzu warranties are subject to mandatory prescribed terms under Australian Consumer law including customer guarantees. For more details visit the Isuzu website which explains Isuzu warranties in more detail, or alternatively contact your local dealer. All warranties commence from date of delivery.

ISUZU AUSTRALIA LIMITED ABN 97 006 962 572 ("IAL"). The information in this spec sheet was correct at time of printing, but all measurements, specifications and equipment are subject to change without notice. Some equipment may have been changed and/or is available at extra cost. IAL may make changes at any time without notice, in prices, colours, materials, equipment and models. IAL makes all reasonable attempts to ensure the availability of all vehicles and equipment. The information in this spec sheet is general in nature. Your Isuzu dealer can confirm all measurements, specifications and vehicle / equipment availability upon request. To the extent permitted by the law, IAL is not liable to any person as result of reliance on the content of this spec sheet.