

# ISUZU

## SPECIFICATIONS

### NPR 75-190 TIPPER



AUSTRALIA'S TOP SELLING TRUCK BRAND SINCE 1989.

#### AT A GLANCE

GVM	7,500 kg
GCM	11,000 kg
Power	140 kW @ 2,600 rpm
Torque	513 Nm @ 1,600 - 2,600 rpm

#### ADVANCED TECHNOLOGY

Emissions: Euro V / ADR 80/03  
Driver and passenger airbag with seatbelt pretensioner  
ECE-R29 compliant cab  
Anti-lock Braking System (ABS)  
Stability Control System (IESC)  
Anti Skid Regulator (ASR)

Hill Assist  
Electric mirrors  
Cruise control  
Front and rear stabiliser bars  
Driver suspension seat  
Cornering lamps



# ISUZU

RELIABILITY IS EVERYTHING

# NPR 75-190 TIPPER

## DRIVELINE AND CHASSIS SPECIFICATIONS

### ENGINE: ISUZU 4HK1-TCC

- Type:** 4 cylinder 16 valve SOHC  
**Displacement:** 5,193 cc  
**Compression ratio:** 17.5:1  
**Bore x Stroke:** 115 mm x 125 mm  
**Max power (DIN-NET):** 140 kW (188HP) @ 2,600 PRM  
**(JIS Gross):** 145 kW (194HP) @ 2,600 RPM  
**Max torque (DIN-NET):** 513 Nm (378 lb.ft) @ 1,600 - 2,600 RPM  
**(JIS Gross):** 531 Nm (392 lb.ft) @ 1,600 - 2,600 RPM  
**Induction system:** Electronically controlled variable nozzle turbocharger with air-to-air intercooler.  
**Fuel injection:** Direct injection high pressure common rail system.  
**Emission control system:** Cooled EGR with exhaust Diesel Oxidation Catalyst (DOC). ADR 80/03 (Euro V) compliant.

### CLUTCH

- Auto adjusting hydraulic control with vacuum assistance. Single plate 325 mm diameter.
- Total lining area: 966 cm<sup>2</sup>

### TRANSMISSION

#### ISUZU MZZ-6F

- 6 speed manual. Synchronesh on gears 1-6.
  - Gear ratios (: 1)
- | 1st   | 2nd   | 3rd   | 4th   | 5th   | 6th   | Rev   |
|-------|-------|-------|-------|-------|-------|-------|
| 6.369 | 3.767 | 1.966 | 1.355 | 1.000 | 0.782 | 6.369 |

### AXLES

- Front:** Isuzu F031
- Reverse Elliot I-beam. 3,100 kg capacity.
- Rear:** Isuzu R066
- Full floating Banjo type. Four differential pinions. 6,600 kg capacity.
  - Drive ratio: 3.909:1

### SUSPENSION

- Front:**
- Single stage alloy steel multi-leaf springs.
  - Double acting hydraulic shock absorbers. Stabiliser bar.
- Rear:**
- Multi-leaf main spring, multi-leaf helper spring.
  - Double acting hydraulic shock absorbers. Stabiliser bar

### BRAKES

- Auto adjusting front and rear disc brakes with dual circuit hydraulic control, integrated boost assist and electronic brake force distribution (EBD).
- ABS, ASR traction control, IESC stability control.
- Hill Assist.
- Front disc diameter: 310 mm
- Rear disc diameter: 310 mm
- 203 mm diameter drum park brake mounted on rear of transmission.
- Vacuum controlled exhaust brake.

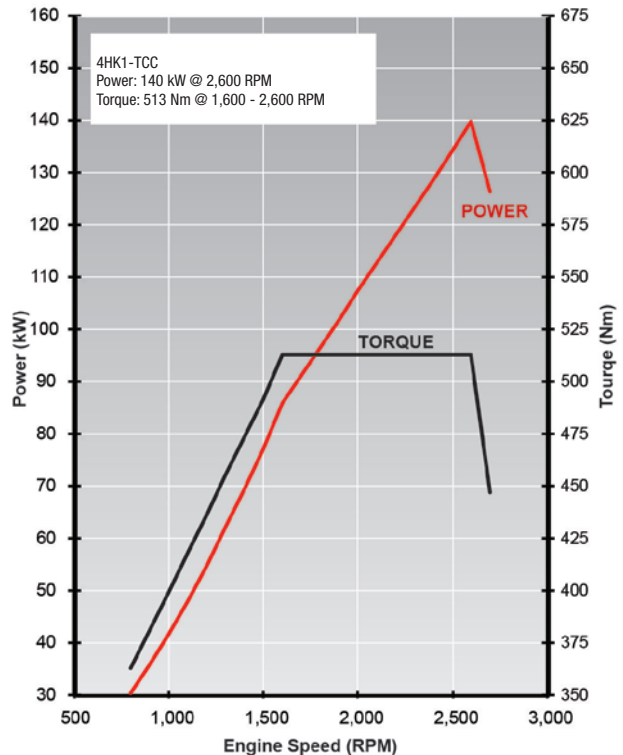

### STEERING

- Power assisted recirculating ball steering.
- Gear ratio: 20.9:1
- Turns lock to lock: 5.4
- Maximum angle: 43° (inside wheel) / 33° (outside wheel)

### WHEELS AND TYRES

- 17.5 x 6.00 six stud steel wheels.
- 205/75R 17.5 124/122M Michelin X Multi Z Tubeless.
- Maximum tyre rating:
  - Steer axle: 3,200 kg
  - Drive axle: 6,000 kg
- 1 frame mounted spare wheel and tyre assembly.

### CHASSIS FRAME

- Cold rivetted ladder frame. SAPH440 weldable steel sidemembers. Parallel side rails and rivetless top flange.
- Frame dimensions:
  - Side rail (mm): 216 x 70 x 6.0
  - Rear frame width (mm): 850

### TIPPER BODY

- All steel body with drop sides. Auto release two-way tailgate.
- Auto release body lockdown hook.
- Shovel rack. LHS and RHS rope rails. Non-slip side steps.
- 20 sec. raise/20 sec. lower time.
- Cubic volume: 3.0 m<sup>3</sup>.
- Deck plate thickness: 3.2 mm.
- Side/front/tail plate thickness: 2.3 mm.

## FUEL TANK

- Frame mounted 140L steel fuel tank.
- Lockable fuel cap.

## ELECTRICAL SYSTEM

- 24 volt electrical system.
- 90 amp alternator.
- 4.5 kW starter motor.
- 2 x 80D26L (630 CCA) batteries connected in series.

## CABIN SPECIFICATIONS AND APPOINTMENTS

### CAB EXTERIOR

- All steel construction. High tensile steel used for cab underframe. Manual cab tilt to 45° with torsion bar assistance.
- Complies with ECE-R29 cab strength standard.
- Liquid filled front and rear cab mounts.
- Heavy duty non slip entry steps.
- 90° opening internally reinforced front doors.
- Water spray suppression guards and front mudflaps.
- Laminated windscreen with shade band.
- Two speed windscreen wipers with intermittent wipe mode.
- Halogen multi-reflector headlamps incorporating turn signals. Additional door mounted integrated side indicator/cornering lamps.
- Combination brake, turn, reverse and marker lamps, registration plate illumination lamps. Reverse alarm.
- Roof-mounted clearance lamps.
- Heated and powered exterior main mirrors with flat glass and additional independently adjustable convex “spot” mirrors.
- Body coloured grille.
- Body coloured impact resisting polycarbonate bumper with steel backing frame.

### CAB INTERIOR

- Contoured adjustable driver's bucket seat with mechanical suspension rated to 130kg.
- Front passenger bench seat with 2 seat capacity.
- 3-point lap sash seatbelts in all outboard seating positions. Driver and outboard front passenger seatbelts fitted with pretensioner. Centre seat lap belts.
- Driver and outboard front passenger airbag.
- Door and roof pillar entry assist grips.
- Full interior trim, padded roof lining and vinyl floor covering. Driver and passenger windscreen header storage shelf.
- Tilt/Telescopic adjustable steering column, soft feel urethane steering wheel.
- Electric windows.
- Central locking with remote keyless entry and immobiliser.
- Twin cup holders. 24V cigarette lighter. Dashboard hook.
- Front door mounted storage pockets and driver's side ashtray.
- Centre console box with storage tray. Fold down storage tray behind centre seat backrest.
- Fully integrated air conditioning and heater/demister with 4-speed fan and outlets for windscreen, side windows, face and floor
- Fluorescent type interior lamp with On/Door/Off switch.
- 2 DIN, two speaker multimedia unit with 6.2" LCD capacitive touch screen. 1.6GHz processor with Android operating system. DAB+ digital radio and fully integrated Bluetooth with voice recognition. Inbuilt PDF, photo and movie viewer. Internet radio accessible via smartphone. 32GB internal file storage. USB and auxilliary input connection provisions.
- DIN sized compartment for storage or for CB radio installation.

### DRIVER CONTROLS

- Key-operated engine start/stop and steering lock. Engine idle speed control.
- Hill Assist slow/fast engagement control and on/off switch.
- ASR and IESC on/off.
- **Left side combination stalk:** Windscreen wipers, washers and exhaust brake.
- **Right side combination stalk:** Turn signals, headlamps, cruise control.
- Tip body raise and lower lever with safety release mechanism.

### INSTRUMENTATION

- Electronically driven speedometer and tachometer. Digital odometer with integrated dual tripmeter. Engine coolant temperature and fuel level gauges.
- **Warning lamps:** Check engine, oil pressure, ABS, SRS airbag, alternator charge, service brakes, park brake, seat belt unfastened, low fuel level.
- **Indicator lamps:** Hill Assist, warm up system, high beam, ASR, IESC, exhaust brake, turn signals, cruise control, PTO engaged.
- **Multi information display:** Shows service interval, instantaneous and average fuel consumption, DPD bar chart, hourmeter, voltmeter, time/day/date and includes 40-120km/h adjustable vehicle speed warning.

### OPTIONS AND GENUINE ACCESSORIES

Include the following (extra cost, request a brochure and further details from your Isuzu dealer):

#### Multimedia unit:

- Telematics system.
- Isuzu satellite navigation including 3 years of free updates.
- Supports up to five camera inputs. One digital camera with infra red and rear microphone input active when reversing, Four analogue cameras.
- Reversing sensors.
- Tyre pressure monitoring system.
- Blind spot viewing cameras.
- ADAS (Advanced Driver Assistance System). Includes lane departure warning, forward collision warning and pedestrian collision alert.
- Wireless inductive phone charger.

#### Other:

- Airbag compatible bullbar.
- Air deflector.

## ISUZU CARE

Isuzu Care gives truck owners access to products and services including Roadside Assist, Service Agreements, Extended Care, Extended Isuzu Assist and the Isuzu Care Centre. Call 1800 035 640.

### WEIGHTS (kg)

Models	Ratings*		Loading Limit* (at ground)		Weight #		
	GVM	GCM	Front	Rear	Front	Rear	Total
NPR 75-190 TIPPER	7,500	11,000	3,100	6,000	1,980	1,630	3,610

\* Vehicle ratings and front/rear weight limits are subject to government regulatory requirements and weight distribution analysis. Consult your Isuzu dealer to select the correct vehicle for your specific application.  
# Vehicle as supplied and including 10 litres of fuel.

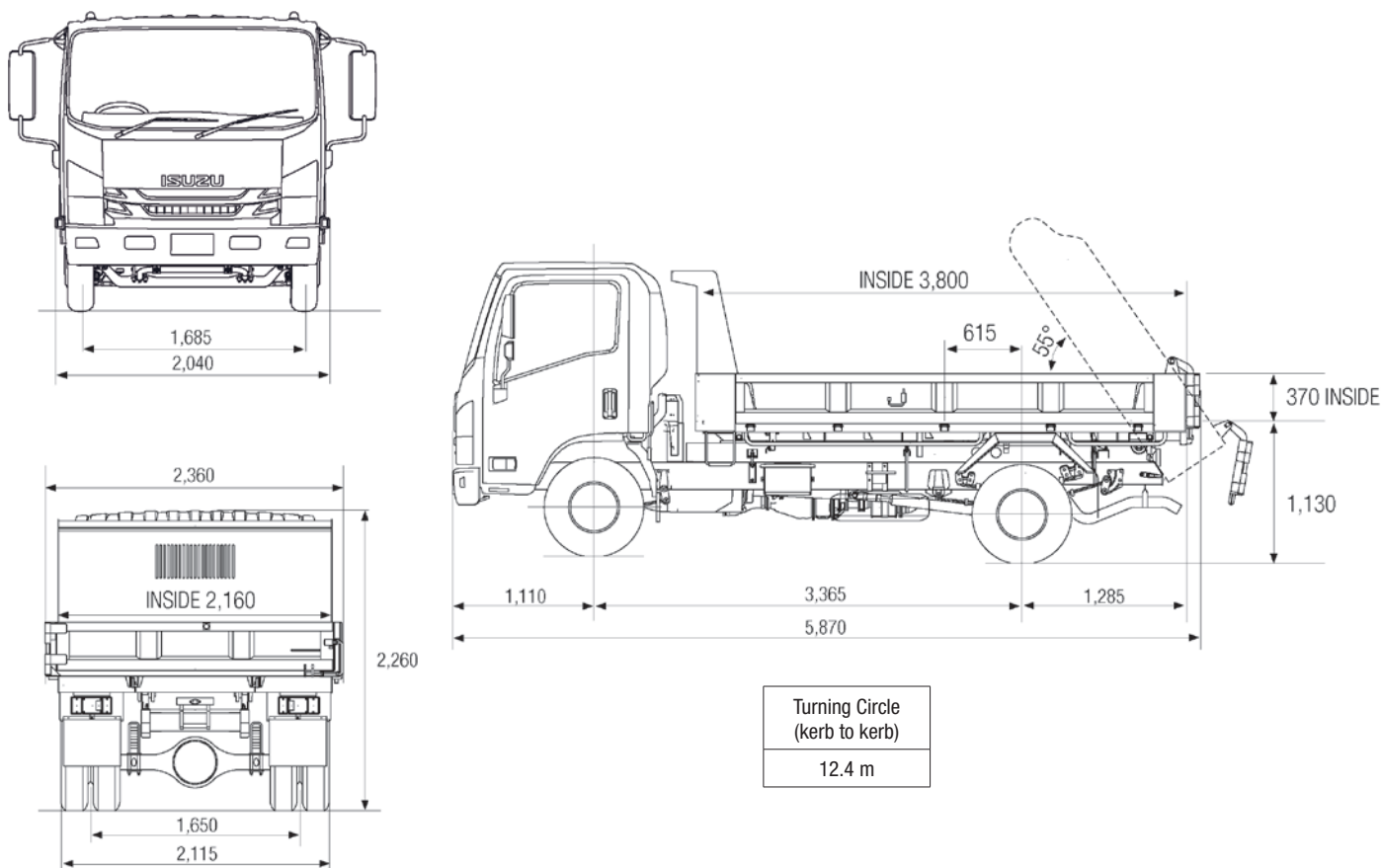

### PERFORMANCE (calculated - typical paved road)

		Geared Speed* (top gear at peak power engine RPM)	Low Speed Gradeability (lowest forward gear assuming no wheel slip)	Engine Speed (top gear at 100km/h)
NPR 75-190 TIPPER	At 7,500 kg GVM	118 km/h @ 2,600 RPM	42%	2,195 RPM

\*Maximum speed achievable depends on vehicle frontal area as well as other factors. Consult your Isuzu dealer for more detailed information.

### ISUZU WARRANTIES

#### STANDARD<sup>1</sup>

New Vehicle 3 years • 100,000km • 2,000 hours

Cab Perforation Corrosion 3 years • unlimited km

Isuzu Assist: 24 hour roadside assistance (3 years, unlimited km)\*

#### EXTENDED CARE<sup>2</sup>

Extended Warranty: 5 years • 250,000km • 4,500 hours

Isuzu Assist: 24 hour roadside assistance (5 years, unlimited km)

### ORDER CODES

Model	Code
NPR 75-190 TIPPER	NH-NPRBC-H18

<sup>1</sup> Subject to the conditions outlined in the IAL New Vehicle Warranty, the Isuzu NPR models carry a standard factory warranty which covers the owner: (i) for the entire vehicle, for the first 36 months or 100,000 km or 2,000 hrs (whichever comes first); (ii) against cab perforation corrosion, for 36 months and unlimited kilometres. <sup>2</sup> Extended Warranty as illustrated may be purchased to cover the owner against the failure of original components, but may exclude some components and expendable items such as oil, filters, etc. \*Valid for three years from the date of new vehicle purchases. All Isuzu warranties are subject to mandatory prescribed terms under Australian Consumer law including customer guarantees. For more details visit the Isuzu website which explains Isuzu warranties in more detail, or alternatively contact your local dealer. All warranties commence from date of delivery. ISUZU AUSTRALIA LIMITED ABN 97 006 962 572 ("IAL"). The information in this spec sheet was correct at time of printing, but all measurements, specifications and equipment are subject to change without notice. Some equipment may have been changed and/or is available at extra cost. IAL may make changes at any time without notice, in prices, colours, materials, equipment and models. IAL makes all reasonable attempts to ensure the availability of all vehicles and equipment. The information in this spec sheet is general in nature. Your Isuzu dealer can confirm all measurements, specifications and vehicle / equipment availability upon request. To the extent permitted by the law, IAL is not liable to any person as result of reliance on the content of this spec sheet.