

## FYJ 300-350 8X4 AGITATOR CAB CHASSIS



### WEIGHT RATINGS\*

GVM	30,000 kg
GCM	45,000 kg

### ENGINE

POWER	257 kW @ 2,000 rpm
TORQUE	1,422 Nm @ 1,400 rpm

### TRANSMISSION

6 speed automatic transmission (AT)

\* Refer to back page for detailed weight rating information

ISUZU CARE	
<b>HARSH APPLICATION WARRANTY (CONCRETE AGITATOR / GARBAGE COMPACTOR)</b>	3 Year Standard Warranty
	300,000 km / no hours stipulation
	3 Year Roadside Support
	24/7 Unlimited km

SERVICE AGREEMENTS			
Optional Service Packages	ESSENTIALS	ESSENTIALS PLUS	TOTAL
<b>SCHEDULED SERVICINGS</b>	●	●	●
<b>CONSUMABLES</b>		●	●
<b>ENGINE, TRANSMISSION &amp; DRIVELINE</b>			●
<b>EXTRAS</b>	After-hours Servicing, Glass, Fuel Card, Pickup - Dropoff		



Subject to the conditions outlined in the IAL New Vehicle Warranty. For further information please visit [isuzu.com.au](http://isuzu.com.au) or contact your local dealer.

INTELLIGENT SAFETY	
<b>STANDARD FEATURES</b>	Anti-Lock Braking System (ABS)
	Electronic Stability Control (ESC)
	Driver airbag
	Driver seatbelt pretensioner
	Low light capable reversing camera

FYJ AGITATOR UNIQUE FEATURE LIST	
<b>POWER TAKE-OFF</b>	Powauto PA44-1JBL11B33B fitted to top opening on transmission
	Constant mesh / continuous engagement
	All helical gears and tapered roller bearings
	851Nm output torque rating
	Output speed 101% of engine
	Rotation direction same as engine (CCW when viewed from cab rear)
	Industry standard SAE 1410 drive flange
<b>DIGITAL CONTROL SYSTEM</b>	Kerb and channel operation mode in adjustable 50 rpm increments between 550 and 950 engine rpm
	Inter axle lock control with override protection against driver engagement error
	Cross lock control with override protection against driver engagement error
	LED beacon and hazard light control linked to kerb and channel mode selection and vehicle speed
	Seat belt warning alarm
	Horn activation warning alarm when door open without handbrake applied
<b>OTHER FEATURES</b>	In cab 12V power outlet
	In cab fire extinguisher
	Emergency warning triangles supplied
	Vocational transmission programming: auto selects neutral when stationary and park brake applied, allows selection of drive from rest only if service brakes applied
	Roof mounted LED light bar and warning beacon
	97dB multi-frequency reverse alarm
Preinstalled chassis outrigger brackets for body mounting	

# FYJ 300-350 8X4 AGITATOR CAB CHASSIS

ENGINE	
<b>DESCRIPTION</b>	Isuzu 6UZ1-TCC
<b>TYPE</b>	6 cylinder 24 valve SOHC
<b>DISPLACEMENT</b>	9,839 cc
<b>COMPRESSION RATIO</b>	17.5:1
<b>BORE X STROKE</b>	120 mm x 145 mm
<b>POWER</b>	257 kW (350PS) @ 2,000 rpm (DIN NET)
<b>TORQUE</b>	1,422 Nm @ 1,400 rpm (DIN NET)
<b>INDUCTION</b>	Electronically controlled variable nozzle turbocharger with air-to-air intercooler
<b>FUEL INJECTION</b>	Direct injection high pressure common rail
<b>EMISSION CONTROL</b>	Cooled EGR with exhaust Diesel Oxidation Catalyst (DOC). ADR 80/03 (Euro V) compliant.

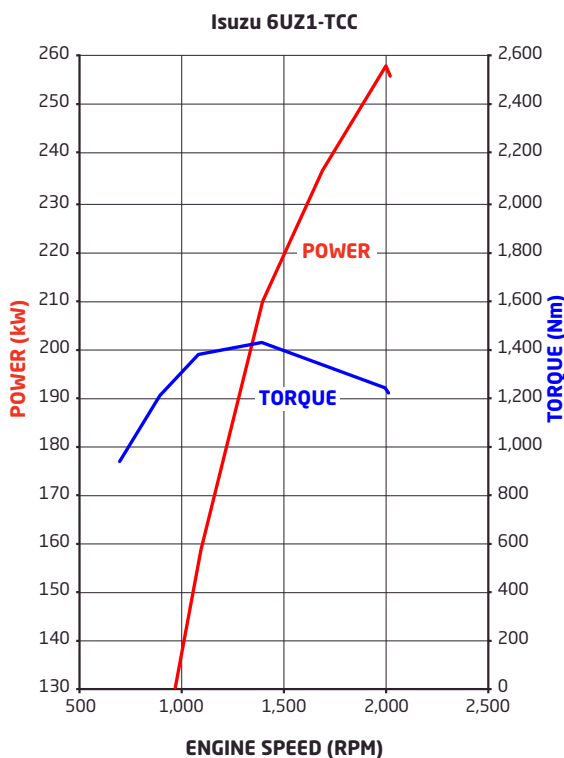

TRANSMISSION															
<b>AT</b>	<b>Description:</b> Allison 4430														
	<b>Type:</b> 6 speed automatic														
	<b>Ratios:</b> <table border="1" style="display: inline-table; vertical-align: middle;"> <thead> <tr> <th>1st</th> <th>2nd</th> <th>3rd</th> <th>4th</th> <th>5th</th> <th>6th</th> <th>Rev</th> </tr> </thead> <tbody> <tr> <td>4.70</td> <td>2.21</td> <td>1.53</td> <td>1.00</td> <td>0.76</td> <td>0.67</td> <td>5.55</td> </tr> </tbody> </table>	1st	2nd	3rd	4th	5th	6th	Rev	4.70	2.21	1.53	1.00	0.76	0.67	5.55
	1st	2nd	3rd	4th	5th	6th	Rev								
4.70	2.21	1.53	1.00	0.76	0.67	5.55									
<b>Power Take Off facility:</b> LHS and top openings on transmission bellhousing. Engine driven PTO drive gear.															
<b>Other features:</b> 6th generation electronic controls with adaptive shift. Long life TranSynd synthetic fluid.															

AXLES	
<b>FRONT</b>	<b>Description:</b> 2 x Meritor FG941
	<b>Type:</b> Reverse Elliot I-beam
	<b>Capacity:</b> 6,600 kg each
<b>REAR</b>	<b>Description:</b> Meritor MT-14X
	<b>Type:</b> Tandem drive
	<b>Other features:</b> Inter-axle lock and cross locks fitted to both axles
	<b>Capacity:</b> 18,100 kg
<b>Ratio:</b> 5.286:1	

SUSPENSION	
<b>FRONT</b>	<b>Type:</b> Single stage alloy steel taper leaf springs
	<b>Load sharing:</b> Front suspension load equaliser and shock absorber
	<b>Other features:</b> Double acting hydraulic shock absorbers fitted to both axles. Stabiliser bar fitted to first front axle.
<b>REAR</b>	<b>Description:</b> Hendrickson HAS461
	<b>Type:</b> Airbag
	<b>Capacity:</b> 20,865 kg at ground

BRAKES	
<b>DESCRIPTION</b>	Meritor 'Q-Plus'
<b>TYPE</b>	Full air 'S-Cam' front and rear drum brakes
<b>DIAMETER X WIDTH FRONT</b>	419 x 152 mm
<b>DIAMETER X WIDTH REAR</b>	419 x 178 mm
<b>PARK BRAKE</b>	Spring park brake acting on all rear wheels
<b>AUXILIARY BRAKE</b>	Air controlled exhaust brake

STEERING	
<b>TYPE</b>	Power assisted recirculating ball
<b>GEAR RATIO</b>	<b>1st axle:</b> 18.8:1
	<b>2nd axle:</b> 22.9:1
<b>TURNS LOCK TO LOCK</b>	3.8
<b>WHEEL LOCK ANGLE</b>	<b>1st axle:</b> 40.0° (inside wheel) / 32.2° (outside wheel)
	<b>2nd axle:</b> 34.0° (inside wheel) / 28.6° (outside wheel)

WHEELS & TYRES		
<b>FRONT</b>	<b>WHEELS</b>	22.5 x 7.50 ten stud ISO standard polished Alcoa aluminium wheels
	<b>TYRES</b>	11R22.5 148/145L Dunlop SP160 Tubeless
	<b>STEER AXLE TYRE RATING</b>	12,600 kg
<b>REAR</b>	<b>WHEELS</b>	22.5 x 7.50 ten stud ISO standard polished Alcoa aluminium wheels
	<b>TYRES</b>	11R22.5 148/145L Dunlop SP431A Tubeless
	<b>TANDEM AXLE TYRE RATING</b>	23,200 kg

CHASSIS FRAME	
<b>TYPE</b>	Cold rivetted ladder frame.
<b>MATERIAL</b>	HT540A steel members
<b>DIMENSIONS</b>	<b>Side rail (mm):</b> 285 x 85 x 7.0 <b>Rear frame width (mm):</b> 850

FUEL TANK	
<b>TYPE</b>	Frame mounted aluminium fuel tank
<b>CAPACITY</b>	200 L
<b>FUEL CAP</b>	Lockable

## CABIN SPECIFICATIONS & APPOINTMENTS

CABIN GENERAL FEATURES	
<b>ENGINE ACCESS</b>	Electro-hydraulic cab tilt
<b>CAB MOUNTING</b>	Rear coil spring suspension with hydraulic shock absorbers
<b>STEPS</b>	Heavy duty anti-slip steps
<b>DOORS</b>	90° opening internally reinforced front doors
<b>MIRRORS</b>	Heated and powered exterior main mirrors with flat glass and additional independently adjustable convex "spot" mirrors
<b>WIPERS</b>	Two speed windscreen wipers with intermittent wipe mode
<b>EXTERIOR LIGHTING</b>	LED main beam and halogen high beam headlamps. Chrome surround.
	Roof mounted clearance lamps
	Front foglamps
<b>AUDIBLE WARNING</b>	Reverse alarm
<b>GRILLE</b>	Chrome
<b>FRONT BUMPER</b>	Body coloured air dam type
<b>SECURITY</b>	Central locking with remote keyless entry and immobiliser

CABIN INTERIOR	
<b>SEATING</b>	Isri 6860/875 NTS air suspension driver's seat
	Front passenger adjustable bucket seat and front centre seat with folding seat back
<b>SEATBELTS</b>	3-point lap sash seatbelts in all outboard seating positions. Driver seatbelt integrated with driver seat. Centre seat lap belts.
<b>STEERING COLUMN</b>	Tilt/telescopic adjustable
<b>ENTRY ASSIST GRIPS</b>	Door and roof pillar mounted
<b>DOOR WINDOWS</b>	Electric control
<b>STORAGE</b>	Overhead compartments
	Twin cup holders
	Centre console box and storage tray
	Passenger glovebox
	Door pockets
<b>POWER OUTLET</b>	24V cigarette lighter
	2.4A high current fast charge USB socket
<b>AIRCONDITIONING</b>	Auto control
<b>INTERIOR LIGHTING</b>	Fluorescent lamp
<b>REAR COMPARTMENT</b>	ADR 42 compliant sleeper with mattress

ELECTRICAL SYSTEM	
<b>TYPE</b>	24 volt
<b>ALTERNATOR</b>	90 amp
<b>STARTER MOTOR</b>	5.0 kW
<b>BATTERY</b>	2 x 115E41L (651 CCA) batteries connected in series
<b>CAN BUS PROVISION</b>	Underdash CAN system access plug for connection to a Fleet Management System (FMS) (not supplied)

MYISUZU CO-PILOT AUDIO VISUAL UNIT	
<b>SCREEN TYPE</b>	10.1" 1080p High Definition with capacitive touch
<b>OPERATING SYSTEM</b>	Android Automotive
<b>NAVIGATION</b>	Truck tailored GPS based system + Live traffic and map content updates via smartphone link (live feed updates are provided for 3 years)
<b>RADIO</b>	AM/FM/DAB+
<b>INTERNAL STORAGE CAPACITY</b>	32GB
<b>SMARTPHONE INTEGRATION</b>	USB 3.0 socket
	Wi-Fi connectivity
	Android Auto / Apple CarPlay compatible
	Phone storage pocket with wireless charging facility

DRIVER CONTROLS	
<b>ENGINE</b>	Idle speed control
<b>TRANSMISSION</b>	Push button gear selection control
<b>GENERAL CONTROLS</b>	Headlamp on/off and levelling, windscreen wipers (2 speed and intermittent modes), washers, exhaust brake, turn signals
	Inter-axle lock and cross lock engage switches

INSTRUMENTATION	
<b>MULTI INFORMATION DISPLAY</b>	Vehicle systems status
	Low fuel level alert
	Fuel consumption information
	Service interval alerts
	Hourmeter
<b>GENERAL INSTRUMENTATION</b>	Adjustable vehicle speed warning
	Speedometer and tachometer
	Digital odometer with integrated dual tripmeters
	Transmission oil level, oil life, filter life, and condition monitor display
	Engine coolant temperature, fuel level and air pressure gauges



# FYJ 300-350 8X4 AGITATOR CAB CHASSIS

WEIGHTS (kg)							
MODELS	RATINGS*		LOADING LIMIT* (at ground)		CAB CHASSIS WEIGHT #		
	GVM	GCM	FRONT	REAR	FRONT	REAR	TOTAL
FYJ 300-350 AGITATOR CAB CHASSIS	30,000	45,000	12,600	18,100	5,835	2,185	8,020

\* Vehicle ratings and front/rear weight limits are subject to government regulatory requirements and weight distribution analysis. Consult your Isuzu dealer to select the correct vehicle for your specific application.

# Cab chassis only as supplied and including 10 litres of fuel.

DIMENSIONS (mm)													(m)
MODELS	WB	OAL	FOH	ROH	EA	CE	RT	ORT	CH	FFA (unladen)	RFA (unladen)	RFH (unladen)	TURNING CIRCLE kerb to kerb
FYJ 300-350 AUTO SWB AGITATOR CAB CHASSIS	5,080	9,030	1,480	2,470	3,870	6,880	1,860	2,445	3,000	925	1,040	1,040	17.9

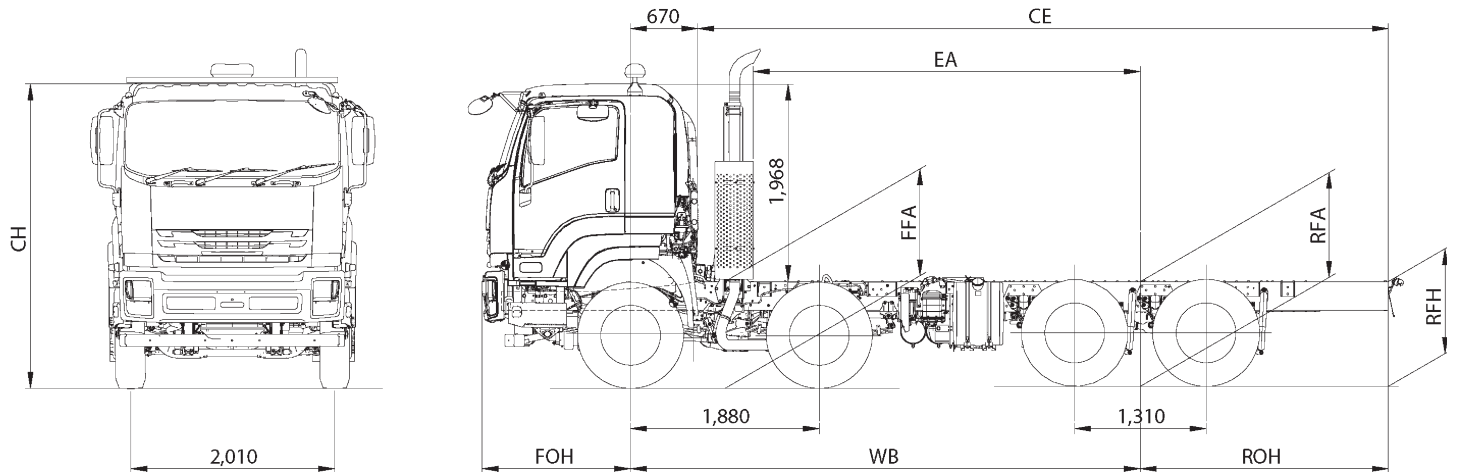

PERFORMANCE (calculated - typical paved road)				
		GEARED SPEED~ (top gear at peak power engine rpm)	LOW SPEED GRADEABILITY (lowest forward gear assuming no wheel slip)	ENGINE SPEED (top gear at 100 km/h)
FYJ 300-350 AGITATOR	At 30,000 kg GVM	109 km/h @ 2,000 RPM	48%	1,830 RPM

~ Maximum speed achievable depends on vehicle frontal area as well as other factors. Consult your Isuzu dealer for more detailed information. Vehicle is speed limited to 100km/h

ORDER CODES	
MODELS	CODES
FYJ 300-350 AUTO AGITATOR CAB CHASSIS	FH-FYJJ-K23

Subject to the conditions outlined in the IAL New Vehicle Warranty, Isuzu FYJ Agitator model carries a standard factory warranty which covers the owner for the first 36 months or 300,000km, whichever occurs first. All Isuzu warranties are subject to mandatory prescribed terms under Australian Consumer Law including consumer guarantees. Harsh Conditions variations to standard factory warranty may apply. For more details visit the Isuzu website at [www.isuzu.com.au](http://www.isuzu.com.au) which explains Isuzu warranties in more detail, or alternatively contact your local Isuzu Truck dealer. All warranties commence from date of initial delivery.

ISUZU AUSTRALIA LIMITED ABN 97 006 962 572 ("IAL"). The information in this spec sheet was correct at time of printing, but all measurements, specifications and equipment are subject to change without notice. Some equipment may have been changed and/or is available at extra cost. IAL may make changes at any time without notice, in prices, colours, materials, equipment and models. IAL makes all reasonable attempts to ensure the availability of all vehicles and equipment. The information in this spec sheet is general in nature. Your Isuzu dealer can confirm all measurements, specifications and vehicle / equipment availability upon request. To the extent permitted by the law, IAL is not liable to any person as result of reliance on the content of this spec sheet.