

ISUZU

SPECIFICATIONS

FRR 600

FRR 600 Crew



FRR 600 Crew



FRR 600

AUSTRALIA'S TOP SELLING TRUCK BRAND SINCE 1989.

AT A GLANCE

GVM	11,000 kg
GCM	16,000 kg
Power	176 kW @ 2,400 rpm
Torque	706 Nm @ 1,450 rpm

UPGRADE OPTIONS

AMT Pack: Automated Manual Transmission (AMT)

Premium Pack: Automated Manual Transmission (AMT), Auto control for air conditioning (except crew), Chrome grille

ADVANCED TECHNOLOGY

Emissions: Euro V / ADR 80/03	Anti Skid Regulator (ASR) - except crew
Meets EEV emissions standard	Hill Start Aid (HSA)
Driver airbag with seatbelt pretensioner	Electric mirrors
ADR42 compliant sleeper - except crew	Front stabiliser bar
ECE-R29 compliant cab	Cruise control
Anti-lock Braking System (ABS)	Isri 6860 seat with integrated seatbelt



THE
one

ISUZU
RELIABILITY IS EVERYTHING

FRR Medium | Long | X-Long | Crew

DRIVELINE AND CHASSIS SPECIFICATIONS

ENGINE: SITEC SERIES III 235 (ISUZU 6HK1-TCN)

- Type:** 6 cylinder 24 valve SOHC
Displacement: 7,790 cc
Compression Ratio: 17.5:1
Bore x Stroke: 115 mm x 125 mm
Max power (DIN-NET): 176 kW (236 HP) @ 2,400 RPM
(JIS Gross): 182 kW (244 HP) @ 2,400 RPM
Max torque (DIN-NET): 706 Nm (521 lb.ft) @ 1,450 RPM
(JIS Gross): 731 Nm (539 lb.ft) @ 1,450 RPM
Induction system: Electronically controlled variable nozzle turbocharger with air-to-air intercooler.
Fuel injection: Direct injection high pressure common rail system.
Emission control system: Cooled EGR with exhaust Diesel Particulate Dif-fuser (DPD). ADR 80/03 (Euro V) compliant. EEV compliant.

CLUTCH

Standard model:

- Air assisted hydraulic control. Single plate 381 mm diameter.
- Total lining area: 1,363 cm²

AMT and Premium Pack:

- Fully automated hydraulically controlled wet clutch and fluid coupling with lock up.

TRANSMISSION

ISUZU MZW-6P

- Synchronesh on gears 2-6. Triple cone synchronesh on 2nd and 3rd gears. Integral oil pump provides full pressure lubrication.
 - PTO provision on LHS of transmission case. PTO drive from mainshaft gear.
 - Gear ratios (:1)
- | 1st | 2nd | 3rd | 4th | 5th | 6th | Rev |
|-------|-------|-------|-------|-------|-------|-------|
| 6.615 | 4.095 | 2.358 | 1.531 | 1.000 | 0.722 | 6.615 |

Standard model:

- 6 speed manual with air assisted shift.

AMT/Premium Pack:

- 6 speed Automated Manual Transmission (AMT) with both fully automatic and clutchless manual operation modes.

AXLES

Front: Isuzu F041

- Reverse Elliot I-beam. 4,100 kg capacity.

Rear: Isuzu R077

- Full floating Banjo type. 7,700 kg capacity.
- Drive ratio: 4.333:1

SUSPENSION

Front:

- Single stage alloy steel taper leaf springs.
- Double acting hydraulic shock absorbers. Stabiliser bar.

Rear:

- Multi leaf main spring, multi leaf helper spring.

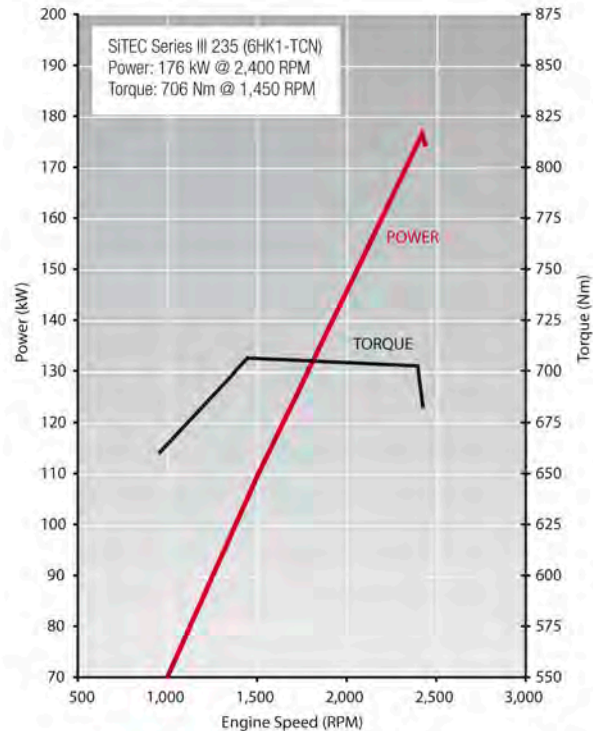

BRAKES

- Dual circuit air over hydraulic front and rear drum brakes.
- ABS.
- ASR traction control (except crew).
- Hill Start Aid (HSA).
- Front drum size: 320 x 120 mm
- Rear drum size: 320 x 145 mm
- Spring park brake.
- Air controlled exhaust brake.
- Air dryer.

STEERING

- Power assisted recirculating ball steering.
- Gear ratio: 16:1 - 18.8:1
- Turns lock to lock: 4.1
- Maximum angle: 52° (inside wheel) / 39° (outside wheel)

WHEELS AND TYRES

- 17.5 x 6.00J six stud steel wheels.
- 235/75R17.5 132/130M Michelin XZE2 Tubeless.
- Maximum tyre rating:
 - Steer axle: 4,000 kg
 - Drive axle: 7,600 kg
- Spare wheel and tyre assembly with winch type carrier.

CHASSIS FRAME

- Cold rivetted ladder frame with parallel side rails. HT540A high tensile weldable steel sidemembers.
- Frame dimensions:
 - Side rail (mm): 225 x 70 x 6.0
 - Rear frame width (mm): 840

FUEL TANK

- Frame mounted 200L steel fuel tank.
- Lockable fuel cap.

ELECTRICAL SYSTEM

- 24 volt electrical system.
- **Single cab:** 60 amp alternator. **Crew cab:** 90 amp alternator.
- 24 Volt, 4.5 kW starter motor.
- 2 x 115E41L (651 CCA) batteries connected in series.

CABIN SPECIFICATIONS AND APPOINTMENTS

CAB EXTERIOR

- All steel construction. High tensile steel used for cab underframe.
 - Single cab:** Manual cab tilt to 45° with torsion bar assistance.
 - Crew cab:** Electro-hydraulic cab tilt.
- Complies with ECE-R29 cab strength standard.
- **Single cab:** Liquid filled front and rear cab mounts.
 - Crew cab:** Rubber cab mounts.
- Heavy duty non slip entry steps.
- 90° opening internally reinforced front doors.
- Water spray suppression guards and front mudflaps.
- Laminated windscreen with shade band.
- Two speed windscreen wipers, with intermittent wipe mode.
- Halogen multi-reflector headlamps incorporating turn signals. Additional door mounted side indicator lamps.
- Combination brake, turn, reverse and marker lamps, registration plate illumination lamps. Extended wiring harness. Reverse alarm.
- Roof-mounted clearance lamps.
- Heated and powered exterior main mirrors with flat glass and additional powered convex "spot" mirrors.
- **Except Premium Pack:** Body coloured grille. **Premium Pack:** Chrome grille.
- Body coloured steel air dam bumper with front foglamps.

CAB INTERIOR

- Isri 6860 air suspension driver's seat with pneumatic lumbar support, height, rake and automatic weight adjustment.
- Front passenger adjustable bucket seat and front centre seat with folding seat back.
- **Crew cab:** Rear bench seat with 4 seat capacity.
- 3-point lap sash seatbelts in all outboard seating positions. Driver seatbelt with pretensioner integrated with driver seat. Centre seat lap belts.
- **Single cab:** ADR42 compliant sleeper.
- Driver airbag.
- **AMT/Premium Pack:** Driver's footrest.
- Door and roof pillar entry assist grips. **Crew cab:** Full width rear grab rail with ashtray.
- Full interior trim, padded roof lining and vinyl floor covering. Driver and passenger windscreen header storage shelf.
- Tilt/Telescopic adjustable steering column, soft feel urethane steering wheel.
- Electric windows.
- Central locking with remote keyless entry and immobiliser.
- Twin cup holders. 24V Cigarette lighter. Dashboard hook.
- Front door mounted storage pockets and driver's side ashtray.
- Centre console box with storage tray. Fold down storage tray behind centre seat backrest.
- Front passenger glovebox.

- Fully integrated air conditioning and heater/demister with 4-speed fan and outlets for windscreen, side windows, face and floor. **Except single cab Premium Pack:** Manual control. **Single cab Premium Pack:** Auto control.
- Fluorescent type interior lamp with On/Door/Off switch.
- 2 DIN, two speaker radio/CD multimedia unit with 4.8" LCD touch screen and Bluetooth. Provision for SD card, USB and 3.5 mm plug inputs.
- DIN sized compartment for storage or for CB radio installation.

DRIVER CONTROLS

- Key-operated engine start/stop and steering lock. Engine idle speed control.
- HSA slow/fast engagement control and on/off switch.
- ASR on/off (except crew).
- DPD regeneration.
- **AMT/Premium Pack:** AMT slow/fast gear engagement control, 1st gear start and normal/economy gear selection modes.
- **Left side combination stalk:** Windscreen wipers, washers and exhaust brake.
- **Right side combination stalk:** Turn signals, headlamps and cruise control.

INSTRUMENTATION

- Electronically driven speedometer and tachometer. Digital odometer with integrated dual tripmeter. Engine coolant temperature, fuel level and air pressure gauges.
- **Warning lamps:** Check engine, oil pressure, ABS, SRS airbag, alternator charge, service brakes, park brake, seatbelt unfastened, low air pressure, low fuel level, cab lock. **AMT/Premium Pack:** Check AMT.
- **Indicator lamps:** HSA, warm up system, high beam, ASR (except crew), DPD status, exhaust brake, turn signals, cruise control. **AMT/Premium Pack:** Econo-mode, 1st gear start.
- **AMT/Premium Pack:** Gear selection display.
- Multi-information display. Shows service interval, instantaneous and average fuel consumption, DPD bar chart, hourmeter, voltmeter, time/day/date and includes 40-120 km/h adjustable vehicle speed warning.

OPTIONS AND GENUINE ACCESSORIES

Include the following (extra cost, request a brochure and further details from your Isuzu dealer):

- Satellite navigation - integrates with multimedia unit and includes NAVTEQ mapping.
- Up to three audio/visual reversing cameras - integrates with multimedia unit.
- Airbag compatible bullbar.
- Air deflector.



ISUZU
RELIABILITY IS EVERYTHING

WEIGHTS (kg)

Models	Ratings*		Loading Limit* (at ground)		Cab Chassis Mass #		
	GVM	GCM	Front	Rear	Front	Rear	Total
FRR 600 Medium	11,000	16,000	4,000	7,600	2,230	1,235	3,465
FRR 600 Medium AMT	11,000	16,000	4,000	7,600	2,245	1,240	3,485
FRR 600 Long	11,000	16,000	4,000	7,600	2,270	1,255	3,525
FRR 600 Long Premium	11,000	16,000	4,000	7,600	2,290	1,260	3,550
FRR 600 X-Long	11,000	16,000	4,000	7,600	2,295	1,255	3,550
FRR 600 Crew	11,000	16,000	4,000	7,600	2,480	1,310	3,790
FRR 600 Crew Premium	11,000	16,000	4,000	7,600	2,495	1,320	3,815

* Vehicle ratings and front/rear weight limits are subject to government regulatory requirements and weight distribution analysis. Consult your Isuzu dealer to select the correct vehicle for your specific application. # Cab chassis only as supplied and including 10 litres of fuel.

DIMENSIONS (mm)

Turn Circle (m)

Models	WB	OAL	FOH	ROH	EA	CE	RT	ORT	CH	FFA (unladen)	RFA (unladen)	RFH (unladen)	KERB TO KERB
FRR 600 Medium	4,360	7,255	1,170	1,725	3,375	5,190	1,660	2,175	2,585	715	895	960	13.9
FRR 600 Long	5,160	8,605	1,170	2,275	4,175	6,540	1,660	2,175	2,585	715	895	950	16.4
FRR 600 X-Long	5,560	9,155	1,170	2,425	4,575	7,090	1,660	2,175	2,585	715	890	960	17.7
FRR 600 Crew	5,160	8,605	1,170	2,275	3,450	5,848	1,660	2,175	2,650	715	895	950	16.4

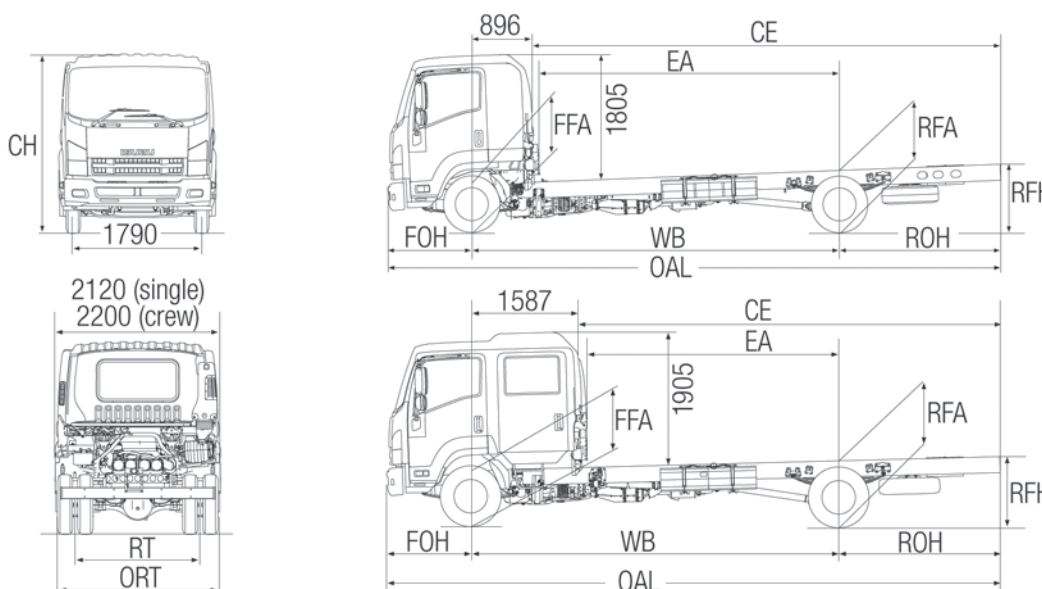

PERFORMANCE (calculated - typical paved road)

		Geared Speed* (top gear at peak power engine RPM)	Low Speed Gradeability (lowest forward gear assuming no wheel slip)	Engine Speed (top gear at 100km/h)
FRR 600	At 11,000kg GVM	112 km/h @ 2,400 RPM	43%	2,145 RPM

*Maximum speed achievable depends on vehicle frontal area as well as other factors. Consult your Isuzu dealer for more detailed information.

ISUZU WARRANTIES

STANDARD ¹			
New Vehicle	3 years • 150,000km • 2,500 hours		
Cab Perforation Corrosion	3 years • unlimited km's		
EXTENDED ²			
4 years, 250,000km	5 years • 300,000km	6 years • 350,000km	
Isuzu Assist - 24 hour roadside assistance (3 years, unlimited km's)*			

ORDER CODES

Model	Code	Model	Code
FRR 600 Medium	FH-FRRCF-B11	FRR 600 X-Long	FH-FRRCF-E11
FRR 600 Medium AMT	FH-FRRCF-G11	FRR 600 Crew	FH-FRRGF-D11
FRR 600 Long	FH-FRRCF-D11	FRR 600 Crew Premium	FH-FRRHF-Z11
FRR 600 Long Premium	FH-FRRDF-Z11		

¹ Subject to the conditions outlined in the IAL New Vehicle Warranty, the Isuzu FRR models carry a standard factory warranty which covers the owner: (i) for the entire vehicle, for the first 36 months or 150,000 km or 2,500 hrs (whichever comes first), (ii) against cab perforation corrosion, for 36 months and unlimited kilometres. ² Extended Warranty as illustrated is available by purchase to cover the owner against the failure of original components, but may exclude some components and expendable items such as oil, filters, etc. Please consult with your Isuzu Dealer for full details obtained from a dedicated brochure available to customers. *Valid for three years from the date of new vehicle purchases.

ISUZU AUSTRALIA LIMITED ABN 97 006 962 572 ("IAL"). The information in this brochure was correct at time of printing, but all measurements, specifications and equipment are subject to change without notice. Some equipment may have been changed and/or is available at extra cost. IAL may make changes at any time without notice, in prices, colours, materials, equipment and models. IAL makes all reasonable attempts to ensure the availability of all vehicles and equipment. The information in this brochure is general in nature. Your Isuzu dealer can confirm all measurements, specifications and vehicle / equipment availability upon request.

TIC: Isuzu is a member of the Truck Industry Council - Safer Greener Essential.

April 2011.ARK0545



ISUZU

RELIABILITY IS EVERYTHING