

REVISION HISTORY				
REV.	ZONE	DESCRIPTION	APPROVED	DATE

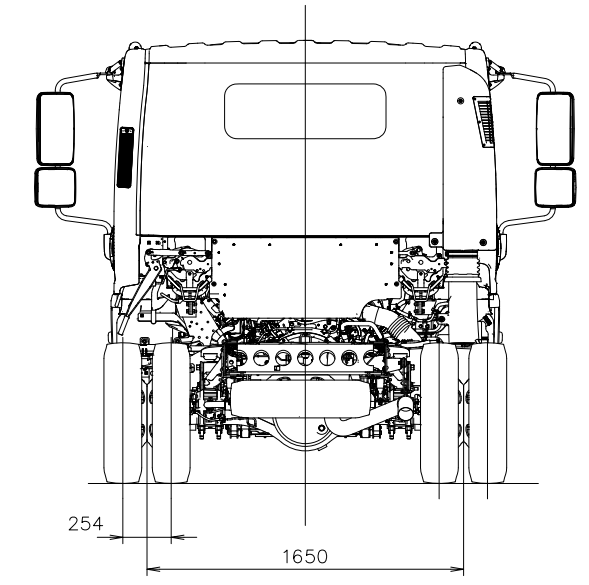
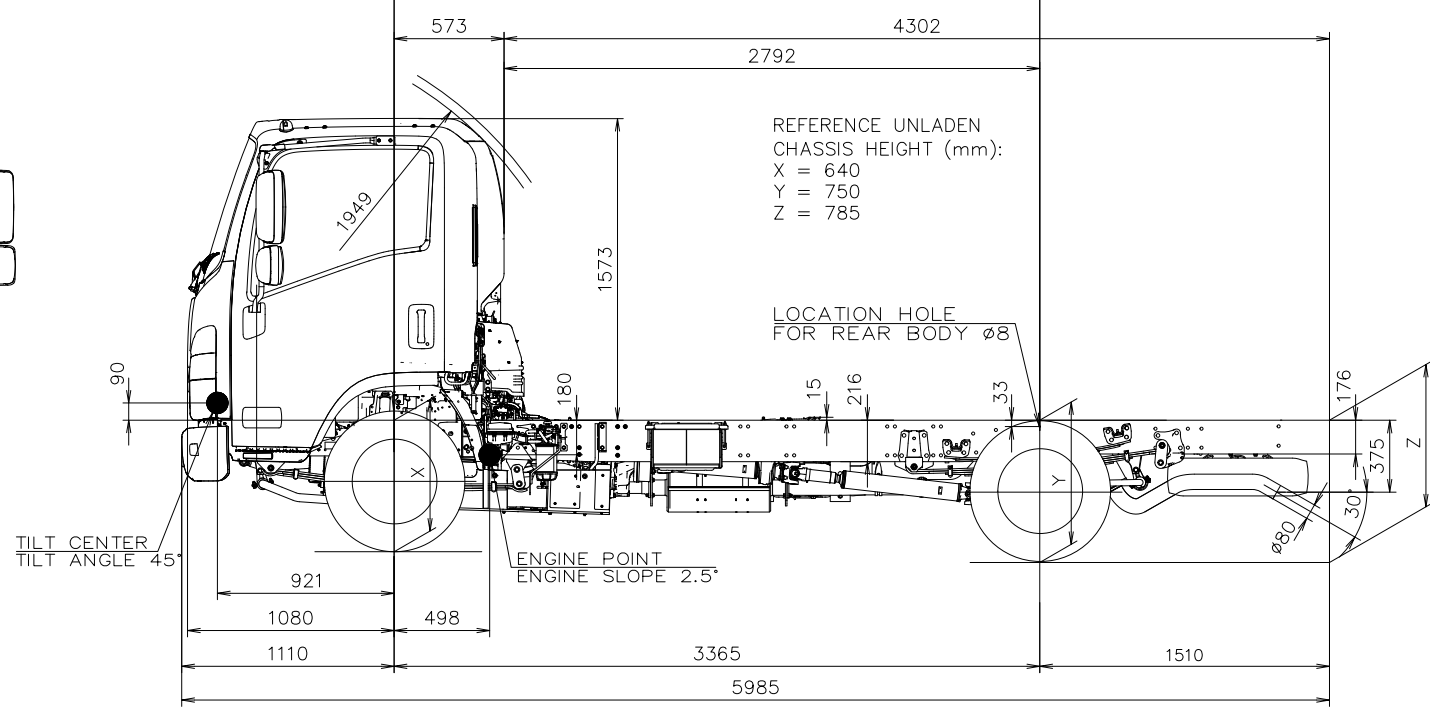
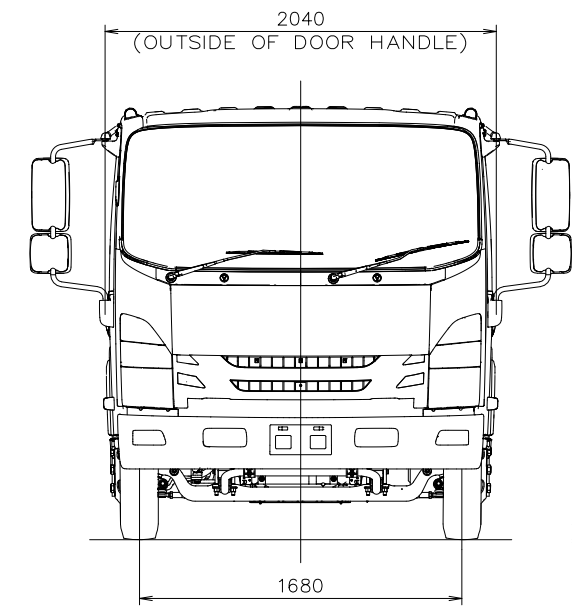
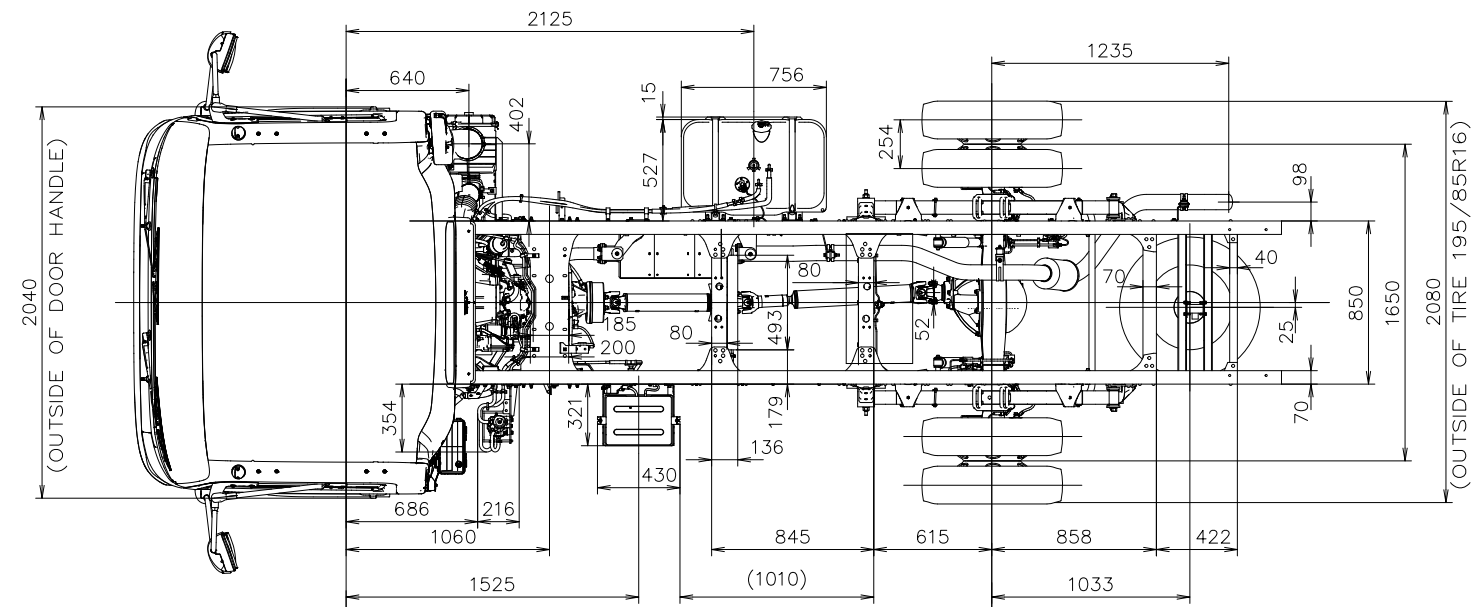

BODY BUILDERS NOTES	
1	DIMENSIONS ARE SHOWN FOR INDICATIVE PURPOSES ONLY
2	REFER TO THE ACTUAL VEHICLES FOR DIMENSIONS

UNLESS OTHERWISE SPECIFIED DIMENSIONS ARE IN MILLIMETERS.

TOLERANCES ARE:
DECIMALS ANGLES
.X +/- 0.8 +/- 2 DEGREES
.XX +/- 0.25

THIRD ANGLE PROJECTION

ISUZU AUSTRALIA Website: ISUZU.COM.AU E-mail: ENGINEERING@ISUZU.NET.AU Office: 66 FOUNDATION ROAD, TRUGANINA, VIC 3029 Correspondence: PO BOX 328, ALTONA NORTH, VIC 3025		© COPY RIGHT 2021 ISUZU AUSTRALIA LIMITED	
		ISUZU JAPAN MODEL CODE NPR75U-HH5VAYHN	
DRAWN W SHEN	DATE 20/08/2021	MODEL NAME MY21 NPR 45/55-155 MWB	
CHECKED S HUMPHRIES	DATE 27/08/2021	MODEL CODE NH-NPRAB-B21	REV. A
APPROVED S HUMPHRIES	DATE 27/08/2021	SHEET SIZE A3	1 OF 1