

NLR 45-150 AMT SERVICEPACK



WEIGHT RATINGS

GVM	4,500 kg
GCM	8,000 kg
TOWING CAPACITY	4,000 kg*

ENGINE

POWER	110 kW @ 2,800 rpm
TORQUE	375 Nm @ 1,600 - 2,800 rpm

TRANSMISSION

6 speed automated manual transmission (AMT)

* Refer to back page for detailed weight rating information

READY TO WORK	
STANDARD FEATURES	Fully powdercoated steel service body
	7 lockable storage compartments with a total volume of 2.5 cubic metres
	2.08 m x 1.0 m (L x W) central storage area with chequerplate floor and 6 tie down points
	Storage compartment locking integrated with vehicle central locking system
	LED lighting in each storage compartment
	Rear barn door for central storage area
	Rear grab handles & non slip step surfaces
	4,000 kg rated towbar with 50mm ball / pintle hook combo attachment.
Isuzu low light capable reversing camera	

SERVICE AGREEMENTS			
Optional Service Packages	ESSENTIALS	ESSENTIALS PLUS	TOTAL
SCHEDULED SERVICINGS	●	●	●
CONSUMABLES		●	●
ENGINE, TRANSMISSION & DRIVELINE			●
EXTRAS	After-hours Servicing, Glass, Fuel Card, Pickup - Dropoff		

INTELLIGENT SAFETY		
ACTIVE SAFETY ADVANCED DRIVER ASSISTANCE SYSTEMS (ADAS)	Advanced Emergency Braking	(AEB)
	Forward Collision Warning	(FCW)
	Distance Warning System	(DWS)
	Lane Departure Warning	(LDW)
	Traffic Movement Warning	(TMW)
	Electronic Stability Control	(ESC)
	Anti-Skid Regulator	(ASR)
	Anti-Lock Braking System	(ABS)
	Automatic Lighting System (Front & Rear)	(ALS)
	Cab Tilt Warning	(CTW)
PASSIVE SAFETY CABIN OCCUPANT SAFETY SYSTEMS (COSS)	Driver & front passenger airbags	
	Driver & front left hand passenger seatbelt pretensioners	
	ECE-R29 cab with side anti-intrusion beams	
	Overhead shelf restraint netting	
	Door mounted cornering lamps	

ISUZU CARE	
WARRANTY	6 Year Standard Warranty
	250,000 km / Unlimited Hours
	3 Year / Unlimited km Body Equipment
ROADSIDE ASSIST	6 Year Roadside Support
	24/7 Unlimited km



Subject to the conditions outlined in the IAL New Vehicle Warranty. For further information please visit isuzu.com.au or contact your local dealer.

NLR 45-150 AMT SERVICEPACK

ENGINE	
DESCRIPTION	Isuzu 4JJ1-TCS
TYPE	4 cylinder 16 valve with chain driven DOHC
DISPLACEMENT	2,999 cc
COMPRESSION RATIO	17.5:1
BORE X STROKE	95.4 mm x 104.9 mm
POWER	110 kW (150PS) @ 2,800 rpm (DIN NET)
TORQUE	375 Nm @ 1,600 - 2,800 rpm (DIN NET)
INDUCTION	Electronically controlled variable nozzle turbocharger with air-to-air intercooler
FUEL INJECTION	Direct injection high pressure common rail
EMISSION CONTROL	Cooled EGR with exhaust Diesel Particulate Diffuser (DPD). ADR 80/03 (Euro V / EEV) compliant.

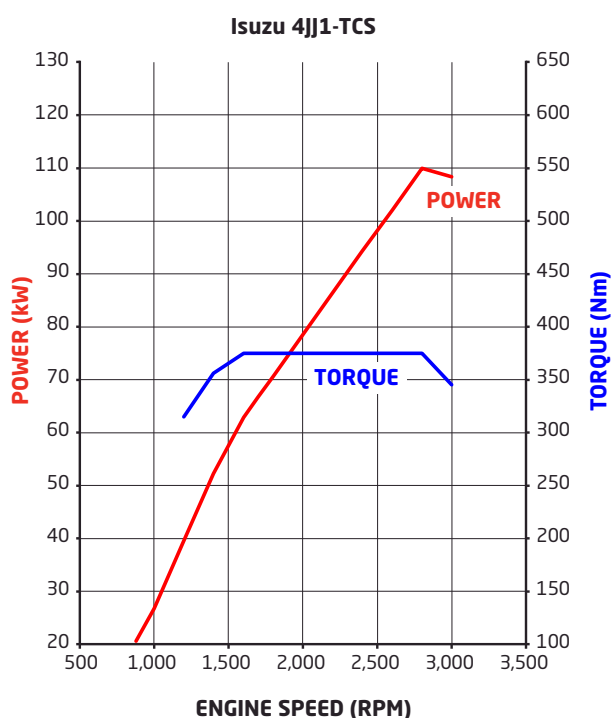

CLUTCH	
AMT	Type: Fully automated electro/hydraulically controlled wet clutch and torque converter (TC) with lock up

TRANSMISSION															
AMT	<p>Description: Isuzu MYY-6E</p> <p>Type: 6 speed with both fully automatic and clutchless manual operation modes</p> <p>Ratios:</p> <table border="1"> <thead> <tr> <th>1ST</th> <th>2ND</th> <th>3RD</th> <th>4TH</th> <th>5TH</th> <th>6TH</th> <th>REV</th> </tr> </thead> <tbody> <tr> <td>5.979</td> <td>3.434</td> <td>2.040</td> <td>1.379</td> <td>1.000</td> <td>0.750</td> <td>5.701</td> </tr> </tbody> </table> <p>Power Take Off facility: Provision on LHS of transmission case. Drive from counter gear.</p>	1ST	2ND	3RD	4TH	5TH	6TH	REV	5.979	3.434	2.040	1.379	1.000	0.750	5.701
1ST	2ND	3RD	4TH	5TH	6TH	REV									
5.979	3.434	2.040	1.379	1.000	0.750	5.701									

AXLES	
FRONT	Description: Isuzu FI026
	Type: Independent wishbone
	Capacity: 2,600 kg
REAR	Description: Isuzu R050
	Type: Full floating banjo with four differential pinions
	Capacity: 5,000 kg
	Ratio: 4.100

SUSPENSION	
FRONT	Coil springs Double acting hydraulic shock absorbers
REAR	Taper leaf main, taper leaf helper spring Double acting hydraulic shock absorbers

BRAKES	
TYPE	Ventilated disc/disc with dual circuit hydraulic control, vacuum assistance and electronic brake force distribution (EBD)
DIAMETER FRONT	293 mm
DIAMETER REAR	275 mm
PARK BRAKE	190 mm diameter drum mounted on rear of transmission
AUXILIARY BRAKE	Vacuum controlled exhaust brake

STEERING	
TYPE	Power assisted rack and pinion
TURNS LOCK TO LOCK	4.2
WHEEL LOCK ANGLE	38.00° (inside wheel) / 34.75° (outside wheel)

WHEELS & TYRES	
FRONT	Wheels: 16 x 5.5J five stud steel
	Tyres: 195/75R16C 107/105R Michelin Agilis Tubeless
	Steer axle tyre rating: 1,950 kg
REAR	Wheels: 16 x 5.5J five stud steel
	Tyres: 195/75R16C 107/105R Michelin Agilis Tubeless
	Drive axle tyre rating: 3,700 kg
SPARE	1 frame mounted spare wheel and tyre assembly

CHASSIS FRAME	
TYPE	Cold rivetted ladder frame. SAPH440 steel sidemembers.
DIMENSIONS	Side rail (mm): 180 x 65 x 4.0 Rear frame width (mm): 700

FUEL TANK	
TYPE	Frame mounted steel fuel tank
CAPACITY	75L
FUEL CAP	Lockable

ELECTRICAL SYSTEM	
TYPE	24 volt
ALTERNATOR	90 amp
STARTER MOTOR	4.0 kW
BATTERY	2 x 80D26L (630 CCA) batteries connected in series

CABIN GENERAL FEATURES	
ENGINE ACCESS	Manual cab tilt to 45° with torsion bar assistance
STEPS	Heavy duty anti-slip steps
DOORS	90° opening internally reinforced front doors
MIRRORS	Heated and powered exterior main mirrors with flat glass and additional independantly adjustable convex "spot" mirrors
WIPERS	Two speed windscreen wipers with intermittent wipe mode
EXTERIOR LIGHTING	Multi-reflector halogen headlamps
AUDIBLE WARNING	Reverse alarm
GRILLE	Body coloured
SECURITY	Central locking with remote keyless entry and immobiliser

INSTRUMENTATION	
MULTI INFORMATION DISPLAY	AEB, FCW, DWS, LDW, TMW systems activation alerts
	CTW indicator
	Vehicle systems status
	Low fuel level alert
	Fuel consumption information
	Service interval alerts
GENERAL INSTRUMENTATION	Hourmeter
	Adjustable vehicle speed warning
	Speedometer and tachometer
	Digital odometer with integrated dual tripmeters
	Engine coolant temperature and fuel level gauges

CABIN INTERIOR	
SEATING	Driver's bucket seat equipped with mechanical suspension and weight adjustment to 130kg
	Front passenger bench seat with 2 seat capacity
SEATBELTS	3-point lap sash seatbelts in all outboard seating positions. Centre seat lap belts.
STEERING COLUMN	Tilt / telescopic adjustable
ENTRY ASSIST GRIPS	Door and roof pillar mounted
DOOR WINDOWS	Electric control
STORAGE	Overhead shelf
	Twin cup holders
	Front door pockets
POWER OUTLET	24V cigarette lighter
AIRCONDITIONING	Manual control
INTERIOR LIGHTING	Fluorescent lamp



MYISUZU CO-PILOT AUDIO VISUAL UNIT	
SCREEN TYPE	10.1" 1080p High Definition with capacitive touch
OPERATING SYSTEM	Android Automotive
NAVIGATION	Truck tailored GPS based system + Live traffic and map content updates via smartphone link (live feed updates are provided for 3 years)
RADIO	AM/FM/DAB+
INTERNAL STORAGE CAPACITY	32GB
SMARTPHONE INTEGRATION	USB 3.0 socket
	Wi-Fi connectivity
	Android Auto / Apple CarPlay compatible
	Phone storage pocket



MyISUZU CO-PILOT audio visual unit.

DRIVER CONTROLS	
SAFETY SYSTEMS	AEB on/off, DWS on/off/sensitivity adjust, LDW on/off/sensitivity adjust, TMW on/off, ESC&ASR on/off, headlamps and ALS on/off
ENGINE	Idle speed control
	Cruise control
	DPD manual regeneration switch
TRANSMISSION	Slow/fast gear engagement control, 1st gear start and normal/economy gear selection modes
	Gear selection control with P-R-N-D and sequential shift positions
GENERAL CONTROLS	Windscreen wipers (2 speed and intermittent modes), washers, exhaust brake, turn signals



AMT model shown.

NLR 45-150 AMT SERVICEPACK

WEIGHTS (kg)							
MODELS	RATINGS*		LOADING LIMIT* (at ground)		WEIGHT #		
	GVM	GCM	FRONT	REAR	FRONT	REAR	TOTAL
NLR 45-150 SWB AMT SERVICEPACK	4,500	8,000**	1,950	3,700	1,535	1,350	2,885

* Vehicle ratings and axle weight limits are subject to government regulatory requirements and weight distribution analysis. Consult your Isuzu dealer to select the correct vehicle for your specific application.**4,000kg maximum towing limit applies. Tag trailer weight should not exceed towing vehicle weight. Limit is subject to tow coupling and government regulatory requirements.

Vehicle as supplied and including 10 litres of fuel.

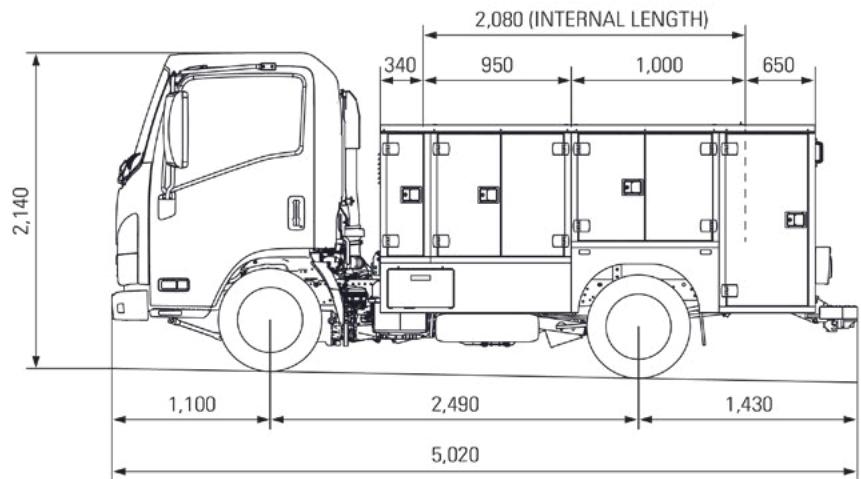
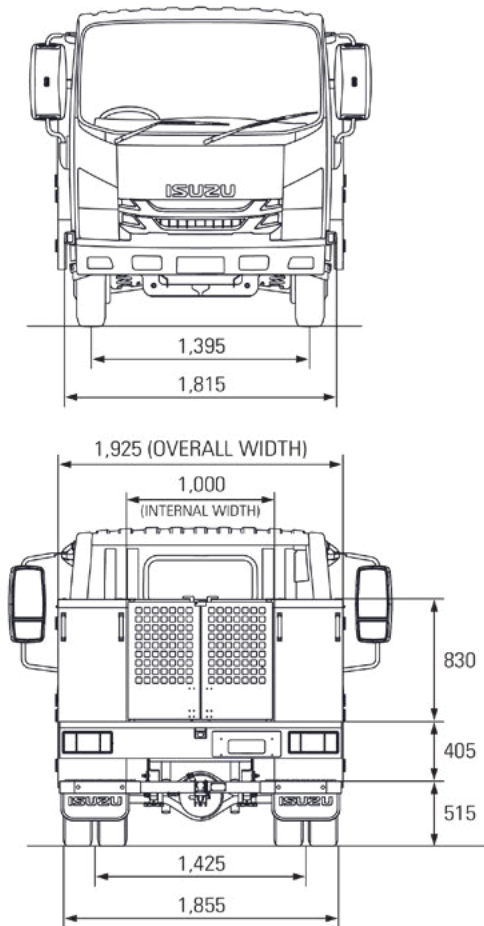

TURNING CIRCLE (kerb to kerb)
8.9 m

PERFORMANCE (calculated - typical paved road)				
		GEARED SPEED* (top gear at peak power engine rpm)	LOW SPEED GRADEABILITY (lowest forward gear assuming no wheel slip)	ENGINE SPEED (top gear at 100 km/h)
NLR 45-150 AMT SERVICEPACK	At 4,500 kg GVM	116 km/h @ 2,800 rpm	56%	2,425 rpm

* Maximum speed achievable depends on vehicle frontal area as well as other factors. Consult your Isuzu dealer for more detailed information.

ORDER CODES	
MODELS	CODES
NLR 45-150 AMT SWB SERVICEPACK	NH-NLRAA-ZC1

Subject to the conditions outlined in the IAL New Vehicle Warranty, 4x2 Isuzu N series models carry a standard factory warranty which covers the owner for the first 72 months or 250,000 kilometres (whichever comes first). All Isuzu warranties are subject to mandatory prescribed terms under Australian Consumer Law including consumer guarantees. The installed Body and associated equipment carry a standard warranty which covers the owner for the first 36 months. For more details visit the Isuzu website at www.isuzu.com.au which explains Isuzu warranties in more detail, or alternatively contact your local Isuzu Truck dealer. All warranties commence from date of initial delivery.

ISUZU AUSTRALIA LIMITED ABN 97 006 962 572 ("IAL"). The information in this spec sheet was correct at time of printing, but all measurements, specifications and equipment are subject to change without notice. Some equipment may have been changed and/or is available at extra cost. IAL may make changes at any time without notice, in prices, colours, materials, equipment and models. IAL makes all reasonable attempts to ensure the availability of all vehicles and equipment. The information in this spec sheet is general in nature. Your Isuzu dealer can confirm all measurements, specifications and vehicle / equipment availability upon request. To the extent permitted by the law, IAL is not liable to any person as result of reliance on the content of this spec sheet.