

NLS 45-150 AWD NLS 45-150 AWD CREW



WEIGHT RATINGS

GVM	4,500 kg
GCM	8,000 kg
TOWING CAPACITY	4,000 kg*

ENGINE

POWER	110 kW @ 2,800 rpm
TORQUE	375 Nm @ 1,600 - 2,800 rpm

TRANSMISSION

5 speed manual transmission (MT)

* Refer to back page for detailed weight rating information

ISUZU CARE	
WARRANTY	3 Year Standard Warranty
	150,000 km / Unlimited Hours
ROADSIDE ASSIST	3 Year Roadside Support
	24/7 Unlimited km

Subject to the conditions outlined in the IAL New Vehicle Warranty. For further information please visit isuzu.com.au or contact your local dealer.

SERVICE AGREEMENTS			
Optional Service Packages	ESSENTIALS	ESSENTIALS PLUS	TOTAL
SCHEDULED SERVICINGS	●	●	●
CONSUMABLES		●	●
ENGINE, TRANSMISSION & DRIVELINE			●
EXTRAS	After-hours Servicing, Glass, Fuel Card, Pickup - Dropoff		

INTELLIGENT SAFETY		
ACTIVE SAFETY ADVANCED DRIVER ASSISTANCE SYSTEMS (ADAS)	Anti-Lock Braking System	(ABS)
	Hill Start Aid (MT model only)	(HSA)
	Automatic Lighting System (Front & Rear)	(ALS)
	Cab Tilt Warning (Single cab only)	(CTW)
PASSIVE SAFETY CABIN OCCUPANT SAFETY SYSTEMS (COSS)	Driver and front passenger airbags	
	Driver and front left hand passenger seatbelt pretensioners	
	ECE-R29 cab with side anti-intrusion beams	
	Overhead shelf restraint netting	
Door mounted cornering lamps		



ENGINE	
DESCRIPTION	Isuzu 4JJ1-TCS
TYPE	4 cylinder 16 valve with chain driven DOHC
DISPLACEMENT	2,999 cc
COMPRESSION RATIO	17.5:1
BORE X STROKE	95.4 mm x 104.9 mm
POWER	110 kW (150 PS) @ 2,800 rpm (DIN NET)
TORQUE	375 Nm @ 1,600 - 2,800 rpm (DIN NET)
INDUCTION	Electronically controlled variable nozzle turbocharger with air-to-air intercooler
FUEL INJECTION	Direct injection high pressure common rail
EMISSION CONTROL	Cooled EGR with exhaust Diesel Particulate Diffuser (DPD). ADR 80/03 (Euro V / EEV) compliant.

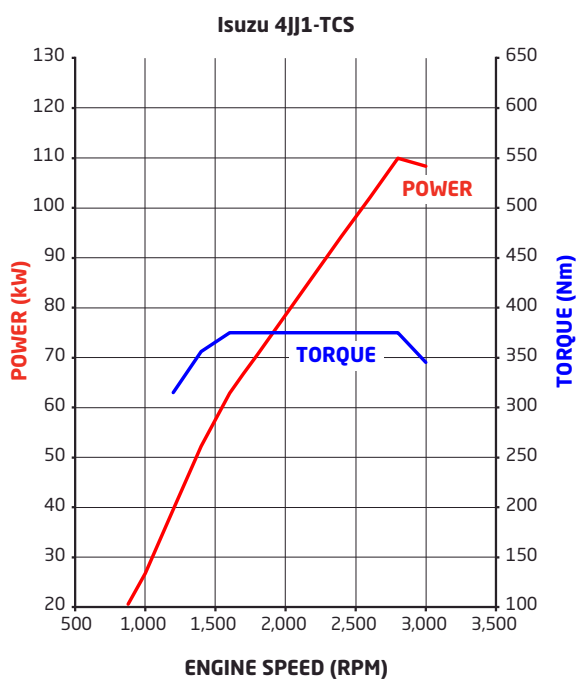

CLUTCH	
MT	<p>Type: Single plate with auto adjusting hydraulic control and vacuum assistance</p> <p>Clutch Plate Diameter: 300 mm</p> <p>Clutch lining area: 847cm²</p>

TRANSMISSION													
MT	<p>Description: Isuzu MYY-5S</p> <p>Type: 5 speed manual. Syncromesh on gears 1-5.</p> <p>Ratios:</p> <table border="1"> <thead> <tr> <th>1ST</th> <th>2ND</th> <th>3RD</th> <th>4TH</th> <th>5TH</th> <th>REV</th> </tr> </thead> <tbody> <tr> <td>5.979</td> <td>3.434</td> <td>1.752</td> <td>1.000</td> <td>0.795</td> <td>5.701</td> </tr> </tbody> </table>	1ST	2ND	3RD	4TH	5TH	REV	5.979	3.434	1.752	1.000	0.795	5.701
1ST	2ND	3RD	4TH	5TH	REV								
5.979	3.434	1.752	1.000	0.795	5.701								
TRANSFER GEARBOX	<p>Type: On demand part time all wheel drive controlled by viscous coupling</p> <p>Ratio: 1.00</p>												

SUSPENSION	
FRONT	<p>Torsion bar springs</p> <p>Double acting hydraulic shock absorbers</p>
REAR	<p>Taper leaf main, taper leaf helper spring</p> <p>Double acting hydraulic shock absorbers</p>

AXLES	
FRONT	<p>Description: Isuzu FD026</p> <p>Type: Fully independent wishbone and final drive with Birfield inner and outer outer joints</p> <p>Hub locking: Manual</p> <p>Capacity: 2,600 kg</p>
REAR	<p>Description: Isuzu R050</p> <p>Type: Full floating banjo with four pinion limited slip differential</p> <p>Capacity: 5,000 kg</p> <p>Ratio: 4.300</p>

BRAKES	
TYPE	Ventilated disc/rear drum with dual circuit hydraulic control, vacuum assistance and electronic brake force distribution (EBD)
DIAMETER FRONT	285 mm
DIAMETER REAR	320 x 75 mm
PARK BRAKE	190 mm diameter drum mounted on rear of transmission
AUXILIARY BRAKE	Vacuum controlled exhaust brake

STEERING	
TYPE	Power assisted rack and pinion
TURNS LOCK TO LOCK	5.0
WHEEL LOCK ANGLE	35.00° (inside wheel) 33.00° (outside wheel)

WHEELS & TYRES	
FRONT	<p>Wheels: 16 x 5.5J five stud steel</p> <p>Tyres: 205/85R16 117/115L Bridgestone G557 Tubeless</p> <p>Steer axle tyre rating: 2,240 kg at 475 KPa inflation pressure</p>
REAR	<p>Wheels: 16 x 5.5J five stud steel</p> <p>Tyres: 205/85R16 117/115L Bridgestone G557 Tubeless</p> <p>Drive axle tyre rating: 4,240 kg at 475 KPa inflation pressure</p>
SPARE	1 frame mounted spare wheel and tyre assembly

CHASSIS FRAME	
TYPE	Cold rivetted ladder frame. SAPH440 steel sidemembers
DIMENSIONS	<p>Side rail (mm): 180 x 65 x 4.0</p> <p>Rear frame width (mm): 700</p>

FUEL TANK	
TYPE	Frame mounted steel fuel tank
CAPACITY	75L
FUEL CAP	Lockable

ELECTRICAL SYSTEM	
TYPE	24 volt
ALTERNATOR	90 amp
STARTER MOTOR	4.0 kW
BATTERY	2 x 80D26L (630 CCA) batteries connected in series

CABIN GENERAL FEATURES	
ENGINE ACCESS	Single cab: manual cab tilt to 45° with torsion bar assistance Crew cab: access hatch under driver's seat and tiltable front passenger seat
STEPS	Heavy duty anti-slip steps
DOORS	90° opening internally reinforced front doors
MIRRORS	Heated and powered exterior main mirrors with flat glass and additional independantly adjustable convex "spot" mirrors
WIPERS	Two speed windscreen wipers with intermittent wipe mode
EXTERIOR LIGHTING	Multi-reflector halogen headlamps
AUDIBLE WARNING	Reverse alarm
GRILLE	Body coloured
SECURITY	Central locking with remote keyless entry and immobiliser

INSTRUMENTATION	
MULTI INFORMATION DISPLAY	Single cab: CTW indicator
	Vehicle systems status
	Low fuel level alert
	Fuel consumption information
	Service interval alerts
GENERAL INSTRUMENTATION	Hourmeter
	Adjustable vehicle speed warning
	Speedometer and tachometer
	Digital odometer with integrated dual tripmeters
	Engine coolant temperature and fuel level gauges

CABIN INTERIOR	
SEATING	Driver's bucket seat
	Front passenger bench seat with 2 seat capacity
	Crew cab: Rear bench seat with 3 seat capacity
SEATBELTS	3-point lap sash seatbelts in all outboard seating positions. Centre seat lap belts.
STEERING COLUMN	Tilt/telescopic adjustable
ENTRY ASSIST GRIPS	Door and roof pillar mounted
DOOR WINDOWS	Electric control
STORAGE	Overhead shelf
	Twin cup holders
	Front door pockets
POWER OUTLET	24V cigarette lighter
AIRCONDITIONING	Manual control
INTERIOR LIGHTING	Single cab: fluorescent lamp Crew cab: standard lamp

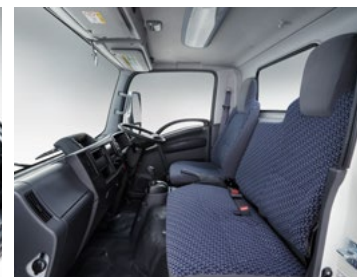

MYISUZU CO-PILOT AUDIO VISUAL UNIT	
SCREEN TYPE	10.1" 1080p High Definition with capacitive touch
OPERATING SYSTEM	Android Automotive
NAVIGATION	Truck tailored GPS based system + Live traffic and map content updates via smartphone link (live feed updates are provided for 3 years)
RADIO	AM/FM/DAB+
INTERNAL STORAGE CAPACITY	32GB
SMARTPHONE INTEGRATION	USB 3.0 socket
	Wi-Fi connectivity
	Android Auto / Apple CarPlay compatible
	Phone storage pocket



MyISUZU CO-PILOT audio visual unit.

DRIVER CONTROLS	
SAFETY SYSTEMS	Headlamps and ALS on/off, HSA on/off/ sensitivity adjust
ENGINE	Idle speed control
	Cruise control
	DPD manual regeneration switch
GENERAL CONTROLS	Windscreen wipers (2 speed and intermittent modes), washers, exhaust brake, turn signals, all wheel drive engage switch

NLS 45-150 AWD NLS 45-150 AWD CREW

WEIGHTS (kg)							
MODELS	RATINGS*		LOADING LIMIT* (at ground)		CAB CHASSIS WEIGHT #		
	GVM	GCM	FRONT	REAR	FRONT	REAR	TOTAL
NLS 45-150 AWD	4,500	8,000**	2,240	4,240	1,615	635	2,250
NLS 45-150 AWD CREW	4,500	8,000**	2,240	4,240	1,705	680	2,385

* Vehicle ratings and axle weight limits are subject to government regulatory requirements and weight distribution analysis. Consult your Isuzu dealer to select the correct vehicle for your specific application.

**4,000kg maximum towing limit applies. Tag trailer weight should not exceed towing vehicle weight. Limit is subject to government regulatory requirements.

Cab chassis only as supplied and including 10 litres of fuel.

DIMENSIONS (mm)													(m)
MODELS	WB	OAL	FOH	ROH	EA	CE	RT	ORT	CH	FFA (unladen)	RFA (unladen)	RFH (unladen)	TURNING CIRCLE kerb to kerb
NLS 45-150 AWD	2,750	5,240	1,100	1,390	2,020	3,667	1,425	1,860	2,200	640	750	810	10.1
NLS 45-150 AWD CREW	3,360	6,025	1,100	1,565	1,570	3,351	1,425	1,860	2,300	660	740	775	12.3

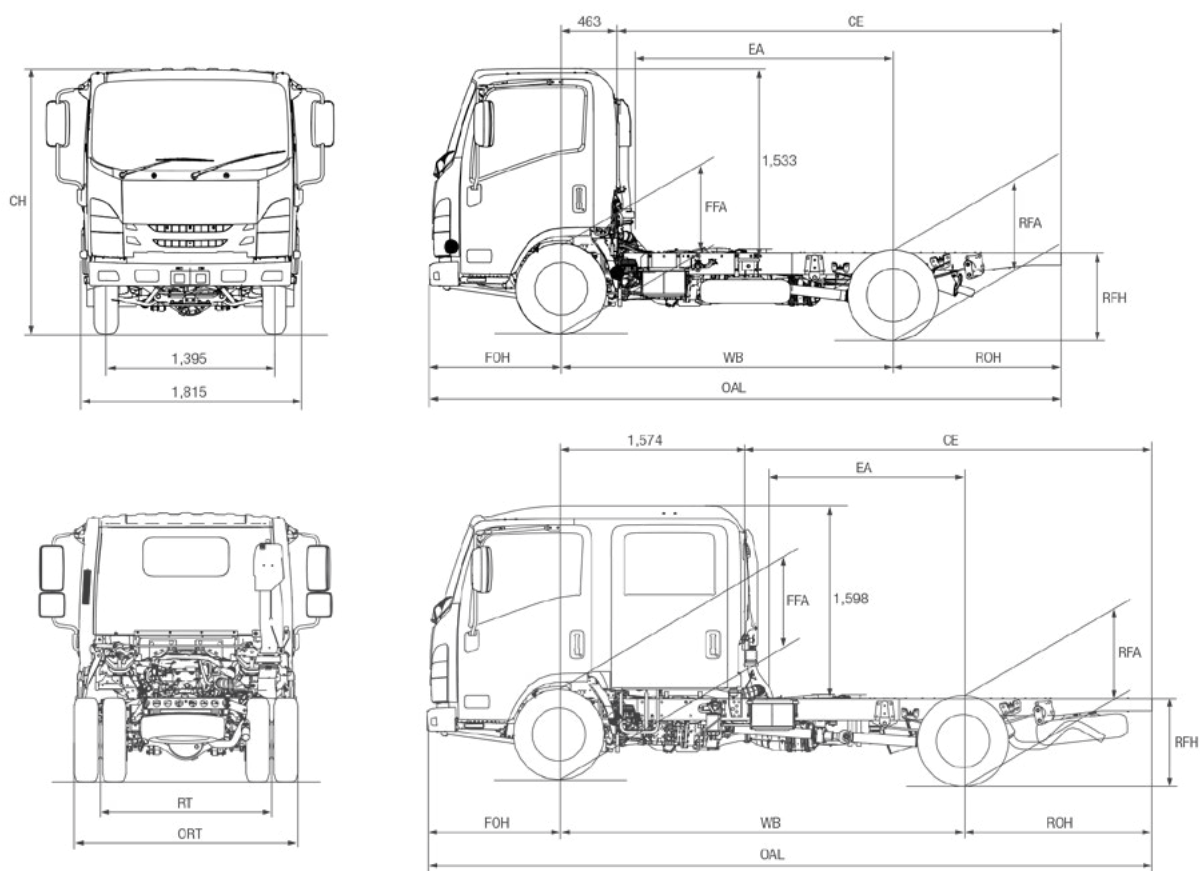

PERFORMANCE (calculated - typical paved road)				
		GEARED SPEED* (top gear at peak power engine rpm)	LOW SPEED GRADEABILITY (lowest forward gear assuming no wheel slip)	ENGINE SPEED (top gear at 100 km/h)
NLS 45-150 AWD	At 4,500 kg GVM	112 km/h @ 2,800 RPM	52%	2,500 rpm

* Maximum speed achievable depends on vehicle frontal area as well as other factors. Consult your Isuzu dealer for more detailed information.

ORDER CODES	
MODELS	CODES
NLS 45-150 AWD	NH-NLSAA-A21
NLS 45-150 AWD CREW	NH-NLSA-B21

Subject to the conditions outlined in the IAL New Vehicle Warranty, 4x4 and AWD Isuzu N series models carry a standard factory warranty which covers the owner for the first 36 months or 150,000 kilometres (whichever comes first). All Isuzu warranties are subject to mandatory prescribed terms under Australian Consumer Law including consumer guarantees. For more details visit the Isuzu website www.isuzu.com.au which explains Isuzu warranties in more detail, or alternatively contact your local Isuzu Truck dealer. All warranties commence from date of initial delivery.

ISUZU AUSTRALIA LIMITED ABN 97 006 962 572 ("IAL"). The information in this spec sheet was correct at time of printing, but all measurements, specifications and equipment are subject to change without notice. Some equipment may have been changed and/or is available at extra cost. IAL may make changes at any time without notice, in prices, colours, materials, equipment and models. IAL makes all reasonable attempts to ensure the availability of all vehicles and equipment. The information in this spec sheet is general in nature. Your Isuzu dealer can confirm all measurements, specifications and vehicle / equipment availability upon request. To the extent permitted by the law, IAL is not liable to any person as result of reliance on the content of this spec sheet.