

NPR 45/55-155



WEIGHT RATINGS

GVM	4,500 kg / 5,500 kg
GCM	9,000 kg
TOWING CAPACITY (AT 4,500KG GVM RATING)	4,500 kg*

ENGINE

POWER	114 kW @ 2,600 rpm
TORQUE	419 Nm @ 1,600 - 2,600 rpm

TRANSMISSION

6 speed manual transmission (MT)
6 speed automated manual transmission (AMT)

* Refer to back page for detailed weight rating information

ISUZU CARE	
WARRANTY	6 Year Standard Warranty
	250,000 km / Unlimited Hours
ROADSIDE ASSIST	6 Year Roadside Support
	24/7 Unlimited km

Subject to the conditions outlined in the IAL New Vehicle Warranty. For further information please visit isuzu.com.au or contact your local dealer.

SERVICE AGREEMENTS			
Optional Service Packages	ESSENTIALS	ESSENTIALS PLUS	TOTAL
SCHEDULED SERVICINGS	●	●	●
CONSUMABLES		●	●
ENGINE, TRANSMISSION & DRIVELINE			●
EXTRAS	After-hours Servicing, Glass, Fuel Card, Pickup - Dropoff		

INTELLIGENT SAFETY			
ACTIVE SAFETY ADVANCED DRIVER ASSISTANCE SYSTEMS (ADAS)	Advanced Emergency Braking	(AEB)	
	Forward Collision Warning	(FCW)	
	Distance Warning System	(DWS)	
	Lane Departure Warning	(LDW)	
	Traffic Movement Warning	(TMW)	
	Electronic Stability Control	(ESC)	
	Anti Skid Regulator	(ASR)	
	Anti Lock Braking System	(ABS)	
	Customisable Speed Limiter	(CSL)	
	Hill Start Aid (MT only)	(HSA)	
	Automatic Lighting System (Front and Rear)	(ALS)	
	Cab Tilt Warning	(CTW)	
	PASSIVE SAFETY CABIN OCCUPANT SAFETY SYSTEMS (COSS)	Driver and front passenger airbags	
		Driver and front left hand passenger seatbelt pretensioners	
ECE-R29 cab with side anti-intrusion beams			
Overhead shelf restraint netting			
	Door mounted cornering lamps		



ENGINE	
DESCRIPTION	Isuzu 4HK1-TCN
TYPE	4 cylinder 16 valve SOHC
DISPLACEMENT	5,193 cc
COMPRESSION RATIO	17.5:1
BORE X STROKE	115 mm x 125 mm
POWER	114 kW (155PS) @ 2,600 rpm (DIN NET)
TORQUE	419 Nm @ 1,600 - 2,600 rpm (DIN NET)
INDUCTION	Electronically controlled variable nozzle turbocharger with air-to-air intercooler
FUEL INJECTION	Direct injection high pressure common rail
EMISSION CONTROL	Cooled EGR with exhaust Diesel Oxidation Catalyst (DOC). ADR 80/03 (Euro V) compliant.

Isuzu 4HK1-TCN

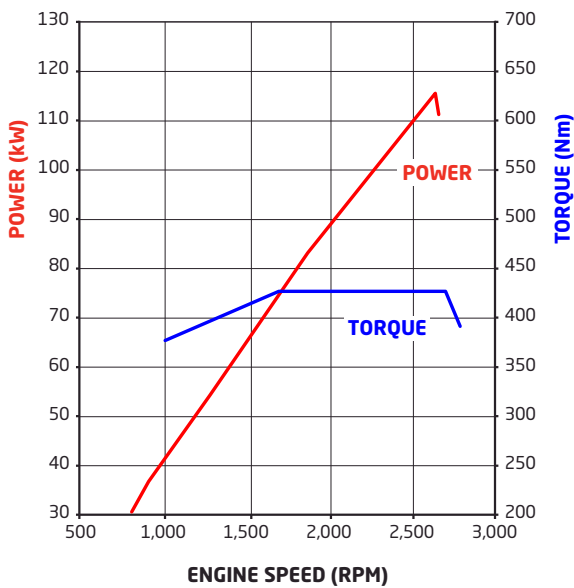

CLUTCH	
MT	<p>Type: Single plate with auto adjusting hydraulic control and vacuum assistance</p> <p>Clutch plate diameter: 325 mm</p> <p>Clutch lining area: 966 cm²</p>
AMT	<p>Type: Fully automated electro/hydraulically controlled wet clutch and torque converter with lock up</p>

TRANSMISSION															
MT	<p>Description: Isuzu MYY-6E</p> <p>Type: 6 speed manual. Syncromesh on gears 1-6.</p>														
	<p>Ratios:</p> <table border="1"> <thead> <tr> <th>1ST</th> <th>2ND</th> <th>3RD</th> <th>4TH</th> <th>5TH</th> <th>6TH</th> <th>REV</th> </tr> </thead> <tbody> <tr> <td>5.979</td> <td>3.434</td> <td>2.040</td> <td>1.379</td> <td>1.000</td> <td>0.750</td> <td>5.701</td> </tr> </tbody> </table>	1ST	2ND	3RD	4TH	5TH	6TH	REV	5.979	3.434	2.040	1.379	1.000	0.750	5.701
	1ST	2ND	3RD	4TH	5TH	6TH	REV								
5.979	3.434	2.040	1.379	1.000	0.750	5.701									
<p>Power Take Off facility: Provision on LHS of transmission case. Drive from counter gear.</p>															
AMT	<p>Description: Isuzu MYY-6E</p> <p>Type: 6 speed with both fully automatic and clutchless manual operation modes</p>														
	<p>Ratios:</p> <table border="1"> <thead> <tr> <th>1ST</th> <th>2ND</th> <th>3RD</th> <th>4TH</th> <th>5TH</th> <th>6TH</th> <th>REV</th> </tr> </thead> <tbody> <tr> <td>5.979</td> <td>3.434</td> <td>2.040</td> <td>1.379</td> <td>1.000</td> <td>0.750</td> <td>5.701</td> </tr> </tbody> </table>	1ST	2ND	3RD	4TH	5TH	6TH	REV	5.979	3.434	2.040	1.379	1.000	0.750	5.701
	1ST	2ND	3RD	4TH	5TH	6TH	REV								
5.979	3.434	2.040	1.379	1.000	0.750	5.701									
<p>Power Take Off facility: Provision on LHS of transmission case. Drive from counter gear.</p>															

AXLES		
FRONT	<p>Description: Isuzu F031</p> <p>Type: Reverse Elliot I-beam</p> <p>Capacity: 3,100 kg</p>	
	REAR	<p>Description: Isuzu R066</p> <p>Type: Full floating banjo with four differential pinions</p> <p>Capacity: 6,600 kg</p> <p>Ratio: 3.909 (MT), 4.100 (AMT)</p>

SUSPENSION	
FRONT	<p>Single stage alloy steel taper leaf springs</p> <p>Double acting hydraulic shock absorbers. Stabiliser bar.</p>
	REAR

BRAKES	
TYPE	Ventilated disc/disc with dual circuit hydraulic control, vacuum assistance and electronic brake force distribution (EBD)
DIAMETER FRONT	293 mm
DIAMETER REAR	293 mm
PARK BRAKE	190 mm diameter drum mounted on rear of transmission
AUXILIARY BRAKE	Vacuum controlled exhaust brake

STEERING	
TYPE	Power assisted recirculating ball
GEAR RATIO	20.9
TURNS LOCK TO LOCK	5.4
WHEEL LOCK ANGLE	43° (inside wheel)
	33° (outside wheel)

WHEELS & TYRES		
FRONT	<p>Wheels: 16 x 5.5J six stud steel</p> <p>Tyres: 195/85R16 114/112L Michelin XJE4 Mix Energy Tubeless</p> <p>Steer axle tyre rating: 2,360 kg</p>	
	REAR	<p>Wheels: 16 x 5.5J five stud steel</p> <p>Tyres: 195/85R16 114/112L Michelin XJE4 Mix Energy Tubeless</p> <p>Drive axle tyre rating: 4,480 kg</p>
		SPARE

CHASSIS FRAME	
TYPE	Cold rivetted ladder frame. SAPH440 steel sidemembers. Parallel side rails and rivetless top flange.
DIMENSIONS	Side rail (mm): 216 x 70 x 6.0
	Rear frame width (mm): 850

FUEL TANK	
TYPE	Frame mounted steel fuel tank
CAPACITY	100L
FUEL CAP	Lockable

ELECTRICAL SYSTEM	
TYPE	24 volt
ALTERNATOR	90 amp
STARTER MOTOR	4.0 kW
BATTERY	2 x 80D26L (630 CCA) batteries connected in series

CABIN GENERAL FEATURES	
ENGINE ACCESS	Manual cab tilt to 45° with torsion bar assistance
STEPS	Heavy duty anti-slip steps
DOORS	90° opening internally reinforced front doors
MIRRORS	Heated and powered exterior main mirrors with flat glass and additional independently adjustable convex "spot" mirrors
WIPERS	Two speed windscreen wipers with intermittent wipe mode
EXTERIOR LIGHTING	Multi-reflector halogen headlamps
	Roof mounted clearance lamps
	Front foglamps
AUDIBLE WARNING	Reverse alarm
GRILLE	Chrome
SECURITY	Central locking with remote keyless entry and immobiliser

INSTRUMENTATION	
MULTI INFORMATION DISPLAY	AEB, FCW, DWS, LDW, TMW systems activation alerts
	CTW indicator
	Low engine oil level alert (activated when oil pan < 71% capacity)
	Vehicle systems status
	Low fuel level alert
	Fuel consumption information
	Service interval alerts
GENERAL INSTRUMENTATION	Hourmeter
	Adjustable vehicle speed warning
	Speedometer and tachometer
	Digital odometer with integrated dual tripmeters
	Engine coolant temperature and fuel level gauges

CABIN INTERIOR	
SEATING	Driver's bucket seat equipped with mechanical suspension and weight adjustment to 130 kg
	Passenger bench seat with 2 seat capacity
SEATBELTS	3-point lap sash seatbelts in all outboard seating positions. Centre seat lap belts.
STEERING COLUMN	Tilt/telescopic adjustable
ENTRY ASSIST GRIPS	Door and roof pillar mounted
DOOR WINDOWS	Electric control
STORAGE	Overhead shelf
	Twin cup holders
	Front centre console box and storage tray
	Front door pockets
POWER OUTLET	24V cigarette lighter
AIR CONDITIONING	Auto control
INTERIOR LIGHTING	Fluorescent lamp



MYISUZU CO-PILOT AUDIO VISUAL UNIT	
SCREEN TYPE	10.1" 1080p High Definition with capacitive touch
OPERATING SYSTEM	Android Automotive
NAVIGATION	Truck tailored GPS based system + Live traffic and map content updates via smartphone link (live feed updates are provided for 3 years)
RADIO	AM/FM/DAB+
INTERNAL STORAGE CAPACITY	32GB
SMARTPHONE INTEGRATION	USB 3.0 socket
	Wi-Fi connectivity
	Android Auto / Apple CarPlay compatible
	Phone storage pocket



MyISUZU CO-PILOT audio visual unit.

DRIVER CONTROLS	
SAFETY SYSTEMS	AEB on/off, DWS on/off/sensitivity adjust, LDW on/off/sensitivity adjust, TMW on/off, ESC&ASR on/off, headlamps and ALS on/off, HSA on/off/sensitivity adjust (MT only)
ENGINE	Idle speed control
	Cruise control
TRANSMISSION (AMT ONLY)	Slow/fast gear engagement control, 1st gear start and normal/economy gear selection modes
	Gear selection control with R-N-D and sequential shift positions
GENERAL CONTROLS	Windscreen wipers (2 speed and intermittent modes), washers, exhaust brake, turn signals



AMT model shown

WEIGHTS (kg)							
MODELS	RATINGS*		LOADING LIMIT* (at ground)		CAB CHASSIS WEIGHT #		
	GVM	GCM	FRONT	REAR	FRONT	REAR	TOTAL
NPR 45/55-155 SWB	4,500/5,500	9,000**	2,360	4,480	1,725	735	2,460
NPR 45/55-155 AMT SWB	4,500/5,500	9,000**	2,360	4,480	1,750	755	2,505
NPR 45/55-155 MWB	4,500/5,500	9,000**	2,360	4,480	1,710	815	2,525
NPR 45/55-155 AMT MWB	4,500/5,500	9,000**	2,360	4,480	1,735	835	2,570

* Vehicle ratings and axle weight limits are subject to government regulatory requirements and weight distribution analysis. Consult your Isuzu dealer to select the correct vehicle for your specific application.

** 4,500kg maximum towing limit applies to 4,500kg GVM rated vehicle. Tag trailer weight should not exceed towing vehicle weight. Limit is subject to government regulatory requirements.

Cab chassis only as supplied and including 10 litres of fuel.

DIMENSIONS (mm)													(m)
MODELS	WB	OAL	FOH	ROH	EA	CE	RT	ORT	CH	FFA (unladen)	RFA (unladen)	RFH (unladen)	TURNING CIRCLE kerb to kerb
NPR 45/55-155 SWB	2,765	5,135	1,100	1,260	2,080	3,452	1,650	2,080	2,270	640	755	795	10.2
NPR 45/55-155 MWB	3,365	5,985	1,100	1,510	2,680	4,302	1,650	2,080	2,270	640	750	785	12.4

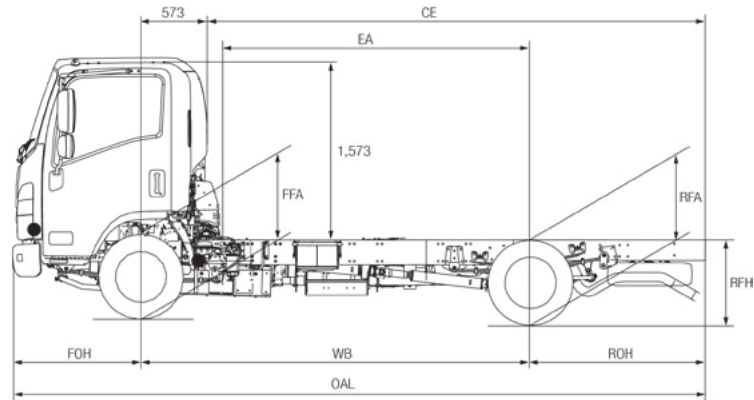
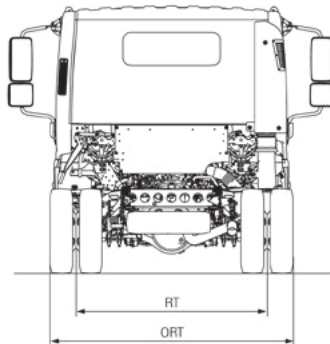
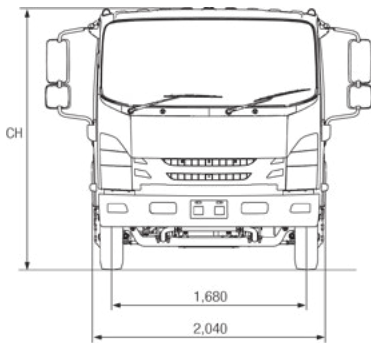

PERFORMANCE (calculated - typical paved road)				
		GEARED SPEED* (top gear at peak power engine rpm)	LOW SPEED GRADEABILITY (lowest forward gear assuming no wheel slip)	ENGINE SPEED (top gear at 100 km/h)
NPR 45-155	At 4,500 kg GVM	114 km/h @ 2,600 RPM	58%	2,275 rpm
NPR 55-155	At 5,500 kg GVM	114 km/h @ 2,600 RPM	47%	2,275 rpm

* Maximum speed achievable depends on vehicle frontal area as well as other factors. Consult your Isuzu dealer for more detailed information.

ORDER CODES	
MODELS	CODES
NPR 45/55-155 SWB	NH-NPRAB-A21
NPR 45/55-155 AMT SWB	NH-NPRAB-Z21
NPR 45/55-155 MWB	NH-NPRAB-B21
NPR 45/55-155 AMT MWB	NH-NPRAB-D21

Subject to the conditions outlined in the IAL New Vehicle Warranty, 4x2 Isuzu N series models carry a standard factory warranty which covers the owner for the first 72 months or 250,000 kilometres (whichever comes first). All Isuzu warranties are subject to mandatory prescribed terms under Australian Consumer Law including consumer guarantees. For more details visit the Isuzu website at www.isuzu.com.au which explains Isuzu warranties in more detail, or alternatively contact your local Isuzu Truck dealer. All warranties commence from date of initial delivery.

ISUZU AUSTRALIA LIMITED ABN 97 006 962 572 ("IAL"). The information in this spec sheet was correct at time of printing, but all measurements, specifications and equipment are subject to change without notice. Some equipment may have been changed and/or is available at extra cost. IAL may make changes at any time without notice, in prices, colours, materials, equipment and models. IAL makes all reasonable attempts to ensure the availability of all vehicles and equipment. The information in this spec sheet is general in nature. Your Isuzu dealer can confirm all measurements, specifications and vehicle / equipment availability upon request. To the extent permitted by the law, IAL is not liable to any person as result of reliance on the content of this spec sheet.