

NPR 75-190 TIPPER



Images throughout may not accurately depict actual specification or they may show extra cost options. Refer written content or contact Isuzu for further details.

WEIGHT RATINGS

GVM	7,500 kg
GCM	11,000 kg

ENGINE

POWER	140 kW @ 2,600 rpm
TORQUE	513 Nm @ 1,600 - 2,600 rpm

TRANSMISSION

6 speed manual transmission (MT)

* Refer to back page for detailed weight rating information

READY TO WORK	
STANDARD FEATURES	All steel body with drop sides
	Auto release two-way tailgate
	Auto release body lockdown hook
	Shovel rack
	LHS and RHS rope rails
	Non-slip side steps
	20 sec. raise / 20 sec. lower time
	Cubic volume: 3.0 m ³
	Deck plate thickness: 3.2 mm
	Side / front / tail plate thickness: 2.3 mm
Isuzu low light capable reversing camera	

SERVICE AGREEMENTS			
Optional Service Packages	ESSENTIALS	ESSENTIALS PLUS	TOTAL
SCHEDULED SERVICINGS	●	●	●
CONSUMABLES		●	●
ENGINE, TRANSMISSION & DRIVELINE			●
EXTRAS	After-hours Servicing, Glass, Fuel Card, Pickup - Dropoff		

INTELLIGENT SAFETY		
ACTIVE SAFETY ADVANCED DRIVER ASSISTANCE SYSTEMS (ADAS)	Advanced Emergency Braking	(AEB)
	Forward Collision Warning	(FCW)
	Distance Warning System	(DWS)
	Lane Departure Warning	(LDW)
	Traffic Movement Warning	(TMW)
	Electronic Stability Control	(ESC)
	Anti-Skid Regulator	(ASR)
	Anti-Lock Braking System	(ABS)
	Customisable Speed Limiter	(CSL)
	Hill Start Aid	(HSA)
	Automatic Lighting System (Front & Rear)	(ALS)
	Cab Tilt Warning	(CTW)
	PASSIVE SAFETY CABIN OCCUPANT SAFETY SYSTEMS (COSS)	Driver & front passenger airbags
Driver & front left hand passenger seatbelt pretensioners		
ECE-R29 cab with side anti-intrusion beams		
Overhead shelf restraint netting		
	Door mounted cornering lamps	

ISUZU CARE	
WARRANTY	6 Year Standard Warranty
	250,000 km / Unlimited Hours
	3 Year / Unlimited km Body Equipment
ROADSIDE ASSIST	6 Year Roadside Support
	24/7 Unlimited km

Subject to the conditions outlined in the IAL New Vehicle Warranty. For further information please visit isuzu.com.au or contact your local dealer.



NPR 75-190 TIPPER

ENGINE	
DESCRIPTION	Isuzu 4HK1-TCC
TYPE	4 cylinder 16 valve SOHC
DISPLACEMENT	5,193 cc
COMPRESSION RATIO	17.5:1
BORE X STROKE	115 mm x 125 mm
POWER	140 kW (190PS) @ 2,600 rpm (DIN NET)
TORQUE	513 Nm @ 1,600 - 2,600 rpm (DIN NET)
INDUCTION	Electronically controlled variable nozzle turbocharger with air-to-air intercooler
FUEL INJECTION	Direct injection high pressure common rail
EMISSION CONTROL	Cooled EGR with exhaust Diesel Oxidation Catalyst (DOC). ADR 80/03 (Euro V) compliant.

Isuzu 4HK1-TCC

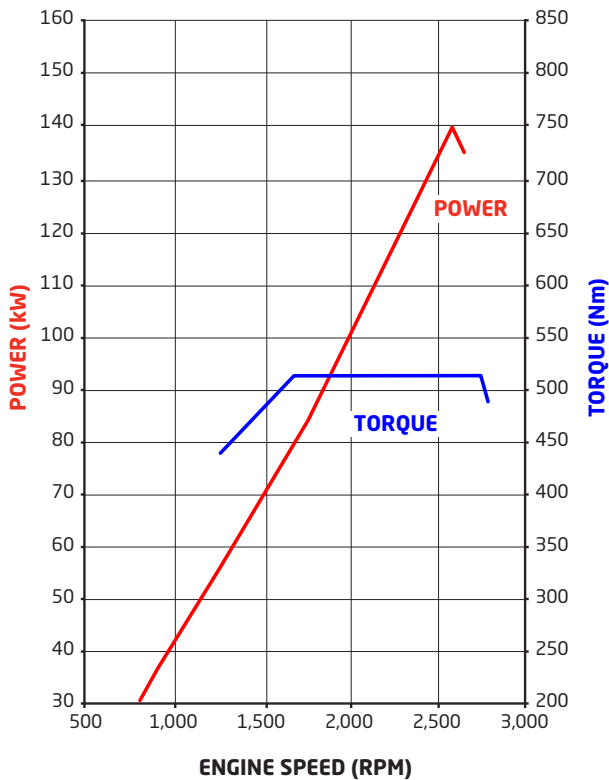

CLUTCH	
MT	<p>Type: Single plate with auto adjusting hydraulic control and vacuum assistance</p> <p>Clutch Plate Diameter: 325 mm</p> <p>Clutch lining area: 966 cm²</p>

TRANSMISSION															
MT	<p>Description: Isuzu MZZ-6F</p> <p>Type: 6 speed manual. Syncromesh on gears 1-6.</p> <p>Ratios:</p> <table border="1"> <thead> <tr> <th>1ST</th> <th>2ND</th> <th>3RD</th> <th>4TH</th> <th>5TH</th> <th>6TH</th> <th>REV</th> </tr> </thead> <tbody> <tr> <td>6.369</td> <td>3.767</td> <td>1.966</td> <td>1.355</td> <td>1.000</td> <td>0.782</td> <td>6.369</td> </tr> </tbody> </table>	1ST	2ND	3RD	4TH	5TH	6TH	REV	6.369	3.767	1.966	1.355	1.000	0.782	6.369
1ST	2ND	3RD	4TH	5TH	6TH	REV									
6.369	3.767	1.966	1.355	1.000	0.782	6.369									

AXLES	
FRONT	<p>Description: Isuzu F031</p> <p>Type: Reverse Elliot I-beam</p> <p>Capacity: 3,100 kg</p>
REAR	<p>Description: Isuzu R066</p> <p>Type: Full floating banjo with four differential pinions</p> <p>Capacity: 6,600 kg</p> <p>Ratio: 3.909</p>

SUSPENSION	
FRONT	<p>Single stage alloy steel taper leaf springs</p> <p>Double acting hydraulic shock absorbers. Stabiliser bar.</p>
REAR	<p>Multi leaf main, multi leaf helper spring</p> <p>Double acting hydraulic shock absorbers. Stabiliser bar.</p>

BRAKES	
TYPE	Ventilated disc/disc with dual circuit hydraulic control, integrated boost assist and electronic brake force distribution (EBD)
DIAMETER FRONT	310 mm
DIAMETER REAR	310 mm
PARK BRAKE	203 mm diameter drum mounted on rear of transmission
AUXILIARY BRAKE	Vacuum controlled exhaust brake

STEERING	
TYPE	Power assisted rack and pinion
GEAR RATIO	20.9
TURNS LOCK TO LOCK	5.4
WHEEL LOCK ANGLE	43° (inside wheel) / 33° (outside wheel)

WHEELS & TYRES	
FRONT	<p>Wheels: 17.5 x 6.00 six stud steel</p> <p>Tyres: 205/75R 17.5 124/122M Michelin X Multi Z Tubeless</p> <p>Steer axle tyre rating: 3,200 kg</p>
REAR	<p>Wheels: 17.5 x 6.00 six stud steel</p> <p>Tyres: 205/75R 17.5 124/122M Michelin X Multi Z Tubeless</p> <p>Drive axle tyre rating: 6,000 kg</p>
SPARE	1 frame mounted spare wheel and tyre assembly

CHASSIS FRAME	
TYPE	Cold rivetted ladder frame. SAPH440 steel sidemembers. Parallel side rails and rivetless top flange.
DIMENSIONS	<p>Side rail (mm): 216 x 70 x 6.0</p> <p>Rear frame width (mm): 850</p>

FUEL TANK	
TYPE	Frame mounted steel fuel tank
CAPACITY	140L
FUEL CAP	Lockable

ELECTRICAL SYSTEM	
TYPE	24 volt
ALTERNATOR	90 amp
STARTER MOTOR	4.0 kW
BATTERY	2 x 80D26L (630 CCA) batteries connected in series

CABIN GENERAL FEATURES	
ENGINE ACCESS	Manual cab tilt to 45° with torsion bar assistance
STEPS	Heavy duty anti-slip steps
DOORS	90° opening internally reinforced front doors
MIRRORS	Heated and powered exterior main mirrors with flat glass and additional independantly adjustable convex "spot" mirrors
WIPERS	Two speed windscreen wipers with intermittent wipe mode
EXTERIOR LIGHTING	Multi-reflector halogen headlamps Roof mounted clearance lamps
AUDIBLE WARNING	Reverse alarm
GRILLE	Body coloured
SECURITY	Central locking with remote keyless entry and immobiliser

CABIN INTERIOR	
SEATING	Driver's bucket seat equipped with mechanical suspension and weight adjustment to 130 kg Front passenger bench seat with 2 seat capacity
SEATBELTS	3-point lap sash seatbelts in all outboard seating positions. Centre seat lap belts.
STEERING COLUMN	Tilt / telescopic adjustable
ENTRY ASSIST GRIPS	Door and roof pillar mounted
DOOR WINDOWS	Electric control
STORAGE	Overhead shelf Twin cup holders Front centre console box and storage tray Front door pockets
POWER OUTLET	24V cigarette lighter
AIRCONDITIONING	Manual control
INTERIOR LIGHTING	Fluorescent lamp

MYISUZU CO-PILOT AUDIO VISUAL UNIT	
SCREEN TYPE	10.1" 1080p High Definition with capacitive touch
OPERATING SYSTEM	Android Automotive
NAVIGATION	Truck tailored GPS based system + Live traffic and map content updates via smartphone link (live feed updates are provided for 3 years)
RADIO	AM/FM/DAB+
INTERNAL STORAGE CAPACITY	32GB
SMARTPHONE INTEGRATION	USB 3.0 socket Wi-Fi connectivity Android Auto / Apple CarPlay compatible Phone storage pocket

DRIVER CONTROLS	
SAFETY SYSTEMS	AEB on/off, DWS on/off/sensitivity adjust, LDW on/off/sensitivity adjust, TMW on/off, ESC&ASR on/off, headlamps and ALS on/off, HSA on/off/sensitivity adjust
ENGINE	Idle speed control Cruise control
GENERAL CONTROLS	Windscreen wipers (2 speed and intermittent modes), washers, exhaust brake, turn signals Tip body raise and lower lever with safety release mechanism

INSTRUMENTATION	
MULTI INFORMATION DISPLAY	AEB, FCW, DWS, LDW, TMW systems activation alerts CTW indicator Low engine oil level alert (activated when oil pan < 71% capacity) Vehicle systems status Low fuel level alert Fuel consumption information Service interval alerts Hourmeter Adjustable vehicle speed warning PTO engaged indicator
GENERAL INSTRUMENTATION	Speedometer and tachometer Digital odometer with integrated dual tripmeters Engine coolant temperature and fuel level gauges



MyISUZU CO-PILOT audio visual unit.

NPR 75-190 TIPPER

WEIGHTS (kg)							
MODELS	RATINGS*		LOADING LIMIT* (at ground)		WEIGHT #		
	GVM	GCM	FRONT	REAR	FRONT	REAR	TOTAL
NPR 75-190 TIPPER	7,500	11,000	3,100	6,000	1,980	1,630	3,610

* Vehicle ratings and front/rear weight limits are subject to government regulatory requirements and weight distribution analysis. Consult your Isuzu dealer to select the correct vehicle for your specific application.

Vehicle as supplied and including 10 litres of fuel.

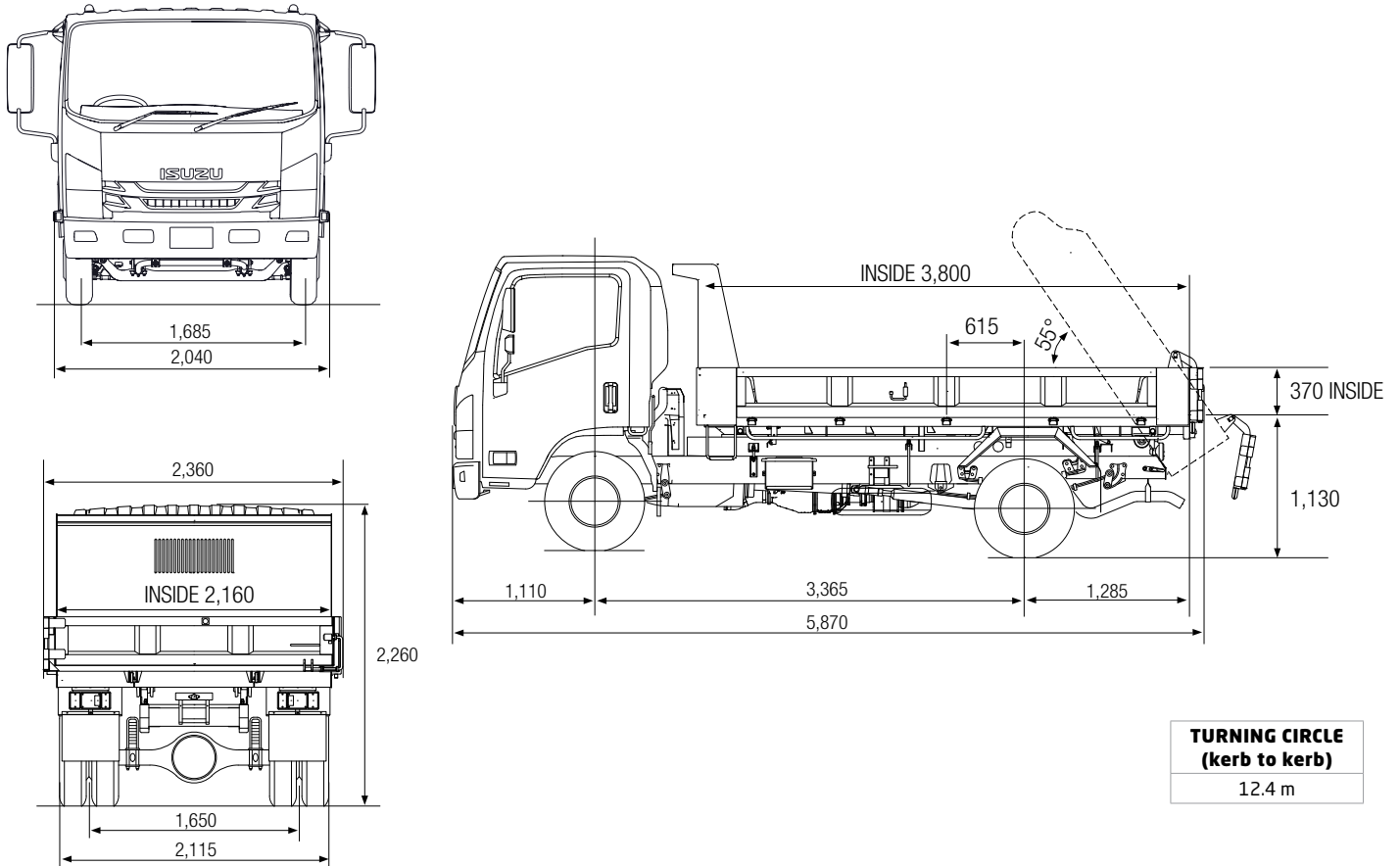

PERFORMANCE (calculated - typical paved road)				
		GEARED SPEED* (top gear at peak power engine rpm)	LOW SPEED GRADEABILITY (lowest forward gear assuming no wheel slip)	ENGINE SPEED (top gear at 100 km/h)
NPR 75-190 TIPPER	At 7,500 kg GVM	118 km/h @ 2,600 rpm	42%	2,195 rpm

* Maximum speed achievable depends on vehicle frontal area as well as other factors. Consult your Isuzu dealer for more detailed information.

ORDER CODES	
MODELS	CODES
NPR 75-190 TIPPER	NH-NPRBC-H21

Subject to the conditions outlined in the IAL New Vehicle Warranty, 4x2 Isuzu N series models carry a standard factory warranty which covers the owner for the first 72 months or 250,000 kilometres (whichever comes first). All Isuzu warranties are subject to mandatory prescribed terms under Australian Consumer Law including consumer guarantees. The installed Body and associated equipment carry a standard warranty which covers the owner for the first 36 months. For more details visit the Isuzu website at www.isuzu.com.au which explains Isuzu warranties in more detail, or alternatively contact your local Isuzu Truck dealer. All warranties commence from date of initial delivery.

ISUZU AUSTRALIA LIMITED ABN 97 006 962 572 ("IAL"). The information in this spec sheet was correct at time of printing, but all measurements, specifications and equipment are subject to change without notice. Some equipment may have been changed and/or is available at extra cost. IAL may make changes at any time without notice, in prices, colours, materials, equipment and models. IAL makes all reasonable attempts to ensure the availability of all vehicles and equipment. The information in this spec sheet is general in nature. Your Isuzu dealer can confirm all measurements, specifications and vehicle / equipment availability upon request. To the extent permitted by the law, IAL is not liable to any person as result of reliance on the content of this spec sheet.