

## NPS 75/45-155 4X4 NPS 75/45-155 4X4 CREW



### WEIGHT RATINGS

|   |                      |
|---|----------------------|
| <b>GVM</b>  | 7,500 kg / 4,500 kg  |
| <b>GCM</b>  | 11,000 kg / 9,000 kg |
| <b>TOWING CAPACITY<br/>(AT 4,500 KG GVM RATING)</b> | 4,500 kg*            |

### ENGINE

|               |                            |
|---------------|----------------------------|
| <b>POWER</b>  | 114 kW @ 2,600 rpm         |
| <b>TORQUE</b> | 419 Nm @ 1,600 - 2,600 rpm |

### TRANSMISSION

|   |
|---|
| 5 speed manual transmission (MT)            |
| 5 speed automated manual transmission (AMT) |

\* Refer to back page for detailed weight rating information

| ISUZU CARE             |                              |
|------------------------|------------------------------|
| <b>WARRANTY</b>        | 3 Year Standard Warranty     |
|                        | 150,000 km / Unlimited Hours |
| <b>ROADSIDE ASSIST</b> | 3 Year Roadside Support      |
|                        | 24/7 Unlimited km            |

Subject to the conditions outlined in the IAL New Vehicle Warranty. For further information please visit [isuzu.com.au](http://isuzu.com.au) or contact your local dealer.

| SERVICE AGREEMENTS                          |   |                 |       |
|---|---|-----------------|-------|
| Optional Service Packages                   | ESSENTIALS  | ESSENTIALS PLUS | TOTAL |
| <b>SCHEDULED SERVICINGS</b>                 | ●   | ●               | ●     |
| <b>CONSUMABLES</b>                          |   | ●               | ●     |
| <b>ENGINE, TRANSMISSION &amp; DRIVELINE</b> |   |                 | ●     |
| <b>EXTRAS</b>                               | After-hours Servicing, Glass, Fuel Card, Pickup - Dropoff |                 |       |

| INTELLIGENT SAFETY   |  |
|--|--|
| <b>ACTIVE SAFETY</b>   | Anti Lock Braking System (active in high range) <b>(ABS)</b> |
|  | Customisable Speed Limiter <b>(CSL)</b>                      |
|  | Hill Start Aid (MT only) <b>(HSA)</b>                        |
|  | Automatic Lighting System (Front and Rear) <b>(ALS)</b>      |
|  | Cab Tilt Warning (single cab only) <b>(CTW)</b>              |
| <b>PASSIVE SAFETY<br/>CABIN OCCUPANT<br/>SAFETY SYSTEMS<br/>(COSS)</b> | Driver and front passenger airbags                           |
|  | Driver and front left hand passenger seatbelt pretensioners  |
|  | ECE-R29 cab with side anti-intrusion beams                   |
|  | Overhead shelf restraint netting                             |
|  | Door mounted cornering lamps                                 |



# NPS 75/45-155 4X4

## NPS 75/45-155 4X4 CREW

| ENGINE                   |  |
|--------------------------|--|
| <b>DESCRIPTION</b>       | Isuzu 4HK1-TCN   |
| <b>TYPE</b>              | 4 cylinder 16 valve SOHC   |
| <b>DISPLACEMENT</b>      | 5,193 cc   |
| <b>COMPRESSION RATIO</b> | 17.5:1   |
| <b>BORE X STROKE</b>     | 115mm x 125mm  |
| <b>POWER</b>             | 114kW (155PS) @ 2,600 rpm (DIN NET)  |
| <b>TORQUE</b>            | 419Nm @ 1,600 - 2,600 rpm (DIN NET)<br>(torque limited to 377Nm when in low range first or reverse gear) |
| <b>INDUCTION</b>         | Electronically controlled variable nozzle turbocharger with air-to-air intercooler                       |
| <b>FUEL INJECTION</b>    | Direct injection high pressure common rail   |
| <b>EMISSION CONTROL</b>  | Cooled EGR with exhaust Diesel Oxidation Catalyst (DOC). ADR 80/03 (Euro V) compliant.                   |

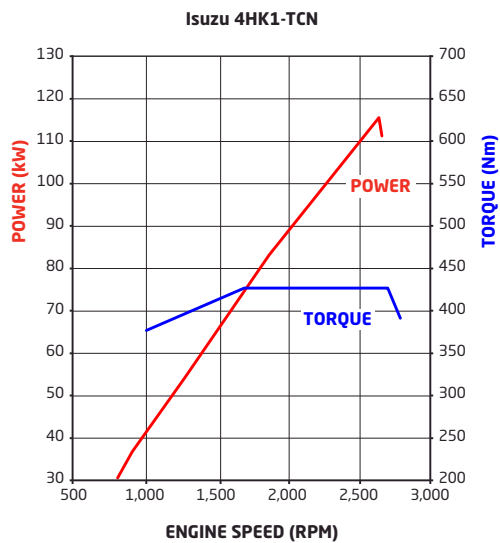

| CLUTCH     |   |
|------------|---|
| <b>MT</b>  | <b>Type:</b> Single plate with auto adjusting hydraulic control and vacuum assistance<br><b>Clutch Plate Diameter:</b> 325 mm<br><b>Clutch lining area:</b> 966 cm <sup>2</sup> |
| <b>AMT</b> | <b>Type:</b> Fully automated electro/hydraulically controlled wet clutch and fluid coupling with lock up  |

| TRANSMISSION            |  |       |       |       |       |     |     |       |       |       |       |       |       |
|-------------------------|--|-------|-------|-------|-------|-----|-----|-------|-------|-------|-------|-------|-------|
| <b>MT</b>               | <b>Description:</b> Isuzu MYY-5A<br><b>Type:</b> 5 speed manual. Syncromesh on gears 1-5.<br><b>Ratios:</b><br><table border="1"> <thead> <tr> <th>1ST</th> <th>2ND</th> <th>3RD</th> <th>4TH</th> <th>5TH</th> <th>REV</th> </tr> </thead> <tbody> <tr> <td>5.315</td> <td>2.908</td> <td>1.558</td> <td>1.000</td> <td>0.721</td> <td>5.068</td> </tr> </tbody> </table> <b>Power Take Off facility:</b> Provision on LHS of transmission case. Drive from counter gear. | 1ST   | 2ND   | 3RD   | 4TH   | 5TH | REV | 5.315 | 2.908 | 1.558 | 1.000 | 0.721 | 5.068 |
| 1ST                     | 2ND  | 3RD   | 4TH   | 5TH   | REV   |     |     |       |       |       |       |       |       |
| 5.315                   | 2.908  | 1.558 | 1.000 | 0.721 | 5.068 |     |     |       |       |       |       |       |       |
| <b>AMT</b>              | <b>Description:</b> Isuzu MYY-5A<br><b>Type:</b> 5 speed manual. Syncromesh on gears 1-5.<br><b>Ratios:</b><br><table border="1"> <thead> <tr> <th>1ST</th> <th>2ND</th> <th>3RD</th> <th>4TH</th> <th>5TH</th> <th>REV</th> </tr> </thead> <tbody> <tr> <td>5.315</td> <td>2.908</td> <td>1.558</td> <td>1.000</td> <td>0.721</td> <td>5.068</td> </tr> </tbody> </table> <b>Power Take Off facility:</b> Provision on LHS of transmission case. Drive from counter gear. | 1ST   | 2ND   | 3RD   | 4TH   | 5TH | REV | 5.315 | 2.908 | 1.558 | 1.000 | 0.721 | 5.068 |
| 1ST                     | 2ND  | 3RD   | 4TH   | 5TH   | REV   |     |     |       |       |       |       |       |       |
| 5.315                   | 2.908  | 1.558 | 1.000 | 0.721 | 5.068 |     |     |       |       |       |       |       |       |
| <b>TRANSFER GEARBOX</b> | <b>Type:</b> Part time 4WD<br><b>Ratio:</b> High: 1.00, Low: 1.842   |       |       |       |       |     |     |       |       |       |       |       |       |

| AXLES        |   |
|--------------|---|
| <b>FRONT</b> | <b>Description:</b> Isuzu FD031<br><b>Type:</b> Full floating Banjo with Birfield outer joints<br><b>Hub locking:</b> Manual<br><b>Capacity:</b> 3,100 kg         |
| <b>REAR</b>  | <b>Description:</b> Isuzu R066<br><b>Type:</b> Full floating banjo with four pinion limited slip differential<br><b>Capacity:</b> 6,600 kg<br><b>Ratio:</b> 5.571 |

| SUSPENSION   |   |
|--------------|---|
| <b>FRONT</b> | Single stage alloy steel multi leaf springs<br>Double acting hydraulic shock absorbers. Stabiliser bar. |
| <b>REAR</b>  | Multi leaf main, multi leaf helper spring<br>Double acting hydraulic shock absorbers                    |

| BRAKES                        |   |
|-------------------------------|---|
| <b>TYPE</b>                   | Drum brakes with dual circuit hydraulic control, hydraulic pressure assistance and load sensing proportioning valve |
| <b>DIAMETER X WIDTH FRONT</b> | 320 x 100mm   |
| <b>DIAMETER X WIDTH REAR</b>  | 320 x 100mm   |
| <b>PARK BRAKE</b>             | 190mm diameter drum mounted on rear of transmission.  |
| <b>AUXILIARY BRAKE</b>        | Vacuum controlled exhaust brake   |

| STEERING                  |  |
|---------------------------|--|
| <b>TYPE</b>               | Power assisted rack and pinion           |
| <b>TURNS LOCK TO LOCK</b> | 3.7                                      |
| <b>WHEEL LOCK ANGLE</b>   | 38° (inside wheel) / 30° (outside wheel) |

| WHEELS & TYRES |   |
|----------------|---|
| <b>FRONT</b>   | <b>Wheels:</b> 17.5 x 6.00 six stud steel wheels<br><b>Tyres:</b> 225 / 80R17.5 123 / 122L Bridgestone L330 Tubeless<br><b>Steer axle tyre rating:</b> 3,100 kg |
| <b>REAR</b>    | <b>Wheels:</b> 17.5 x 6.00 six stud steel wheels<br><b>Tyres:</b> 225 / 80R17.5 123 / 122L Bridgestone L330 Tubeless<br><b>Drive axle tyre rating:</b> 6,000 kg |
| <b>SPARE</b>   | 1 frame mounted spare wheel and tyre assembly   |

| CHASSIS FRAME     |  |
|-------------------|--|
| <b>TYPE</b>       | Cold rivetted ladder frame. SAPH440 steel sidemembers. Parallel side rails and rivetless top flange. |
| <b>DIMENSIONS</b> | <b>Side rail (mm):</b> 216 x 70 x 6.0<br><b>Rear frame width (mm):</b> 850                           |

| FUEL TANK       |                               |
|-----------------|-------------------------------|
| <b>TYPE</b>     | Frame mounted steel fuel tank |
| <b>CAPACITY</b> | 140L                          |
| <b>FUEL CAP</b> | Lockable                      |

| ELECTRICAL SYSTEM    |  |
|----------------------|--|
| <b>TYPE</b>          | 24 volt  |
| <b>ALTERNATOR</b>    | 90 amp   |
| <b>STARTER MOTOR</b> | 4.0 kW   |
| <b>BATTERY</b>       | 2 x 80D26L (630 CCA) batteries connected in series |

| CABIN GENERAL FEATURES   |  |
|--------------------------|--|
| <b>ENGINE ACCESS</b>     | <b>Single cab:</b> manual cab tilt to 45° with torsion bar assistance<br><b>Crew cab:</b> access hatch under driver's seat and tiltable front passenger seat |
| <b>STEPS</b>             | Heavy duty anti-slip steps   |
| <b>DOORS</b>             | 90° opening internally reinforced front doors  |
| <b>MIRRORS</b>           | Heated and powered exterior main mirrors with flat glass and additional independantly adjustable convex "spot" mirrors                                       |
| <b>WIPERS</b>            | Two speed windscreen wipers with intermittent wipe mode  |
| <b>EXTERIOR LIGHTING</b> | Multi-reflector halogen headlamps<br>Roof mounted clearance lamps  |
| <b>AUDIBLE WARNING</b>   | Reverse alarm  |
| <b>GRILLE</b>            | Body coloured  |
| <b>SECURITY</b>          | Central locking with remote keyless entry and immobiliser  |

| INSTRUMENTATION                  |  |
|----------------------------------|--|
| <b>MULTI INFORMATION DISPLAY</b> | <b>Single cab:</b> CTW indicator                                   |
|                                  | Low engine oil level alert (activated when oil pan < 66% capacity) |
|                                  | Vehicle systems status   |
|                                  | Low fuel level alert   |
|                                  | Fuel consumption information                                       |
|                                  | Service interval alerts  |
| <b>GENERAL INSTRUMENTATION</b>   | Hourmeter  |
|                                  | Adjustable vehicle speed warning                                   |
|                                  | Speedometer and tachometer.  |
|                                  | Digital odometer with integrated dual tripmeters                   |
|                                  | Engine coolant temperature and fuel level guages                   |

| CABIN INTERIOR            |  |
|---------------------------|--|
| <b>SEATING</b>            | <b>Single cab:</b> driver's bucket seat equipped with mechanical suspension and weight adjustment to 130 kg<br><b>Crew cab:</b> driver's bucket seat |
|                           | Front passenger bench seat with 2 seat capacity  |
|                           | <b>Crew cab:</b> rear bench seat with 4 seat capacity  |
| <b>SEATBELTS</b>          | 3-point lap sash seatbelts in all outboard seating positions. Centre seat lap belts.   |
| <b>STEERING COLUMN</b>    | Tilt/telescopic adjustable   |
| <b>ENTRY ASSIST GRIPS</b> | Door and roof pillar mounted   |
|                           | <b>Crew cab:</b> full width rear grab rail   |
| <b>DOOR WINDOWS</b>       | Electric control   |
| <b>STORAGE</b>            | Overhead shelf   |
|                           | Twin cup holders   |
|                           | Front centre console box and storage tray  |
|                           | Front door pockets   |
| <b>POWER OUTLET</b>       | 24V cigarette lighter  |
| <b>AIRCONDITIONING</b>    | Manual control   |
| <b>INTERIOR LIGHTING</b>  | <b>Single cab:</b> Fluorescent lamp  |
|                           | <b>Crew cab:</b> Standard lamp   |

| MYISUZU CO-PILOT AUDIO VISUAL UNIT |   |
|------------------------------------|---|
| <b>SCREEN TYPE</b>                 | 10.1" 1080p High Definition with capacitive touch   |
| <b>OPERATING SYSTEM</b>            | Android Automotive  |
| <b>NAVIGATION</b>                  | Truck tailored GPS based system + Live traffic and map content updates via smartphone link (live feed updates are provided for 3 years) |
| <b>RADIO</b>                       | AM/FM/DAB+  |
| <b>INTERNAL STORAGE CAPACITY</b>   | 32GB  |
| <b>SMARTPHONE INTEGRATION</b>      | USB 3.0 socket  |
|                                    | Wi-Fi connectivity  |
|                                    | Android Auto / Apple CarPlay compatible   |
|                                    | Phone storage pocket  |



MyISUZU CO-PILOT audio visual unit.

| DRIVER CONTROLS                |  |
|--------------------------------|--|
| <b>SAFETY SYSTEMS</b>          | Headlamps and ALS on/off, HSA on/off/sensitivity adjust (MT only)  |
| <b>ENGINE</b>                  | Idle speed control   |
|                                | Cruise control   |
| <b>TRANSMISSION (AMT ONLY)</b> | Slow/fast gear engagement control, 1st gear start and normal/economy gear selection modes.                                       |
|                                | Gear selection control with R-N-D and sequential shift positions   |
| <b>GENERAL CONTROLS</b>        | Windscreen wipers (2 speed and intermittent modes), washers, exhaust brake, turn signals, high/low range and 4WD engage switches |



AMT model shown

# NPS 75/45-155 4X4 NPS 75/45-155 4X4 CREW

| WEIGHTS (kg)               |             |                |                            |       |                      |       |       |
|----------------------------|-------------|----------------|----------------------------|-------|----------------------|-------|-------|
| MODELS                     | RATINGS*    |                | LOADING LIMIT* (at ground) |       | CAB CHASSIS WEIGHT # |       |       |
|                            | GVM         | GCM            | FRONT                      | REAR  | FRONT                | REAR  | TOTAL |
| NPS 75/45-155 4X4          | 7,500/4,500 | 11,000/9,000** | 3,100                      | 6,000 | 1,960                | 970   | 2,930 |
| NPS 75/45-155 AMT 4X4      | 7,500/4,500 | 11,000/9,000** | 3,100                      | 6,000 | 1,980                | 970   | 2,950 |
| NPS 75/45-155 4X4 CREW     | 7,500/4,500 | 11,000/9,000** | 3,100                      | 6,000 | 2,100                | 1,070 | 3,170 |
| NPS 75/45-155 AMT 4X4 CREW | 7,500/4,500 | 11,000/9,000** | 3,100                      | 6,000 | 2,120                | 1,070 | 3,190 |

\* Vehicle ratings and axle weight limits are subject to government regulatory requirements and weight distribution analysis. Consult your Isuzu dealer to select the correct vehicle for your specific application. \*\*4,500kg maximum towing limit applies to 4,500kg GVM rated vehicle. Tag trailer weight should not exceed towing vehicle weight. Limit is subject to government regulatory requirements. # Cab chassis only as supplied and including 10 litres of fuel.

| DIMENSIONS (mm)        |       |       |       |       |       |       |       |       |       |               |               |               | (m)                         |
|------------------------|-------|-------|-------|-------|-------|-------|-------|-------|-------|---------------|---------------|---------------|-----------------------------|
| MODELS                 | WB    | OAL   | FOH   | ROH   | EA    | CE    | RT    | ORT   | CH    | FFA (unladen) | RFA (unladen) | RFH (unladen) | TURNING CIRCLE kerb to kerb |
| NPS 75/45-155 4X4      | 3,395 | 5,985 | 1,080 | 1,510 | 2,710 | 4,332 | 1,650 | 2,120 | 2,490 | 850           | 940           | 975           | 13.6                        |
| NPS 75/45-155 4X4 CREW | 3,395 | 5,985 | 1,080 | 1,510 | 1,730 | 3,331 | 1,650 | 2,120 | 2,490 | 850           | 950           | 980           | 13.6                        |

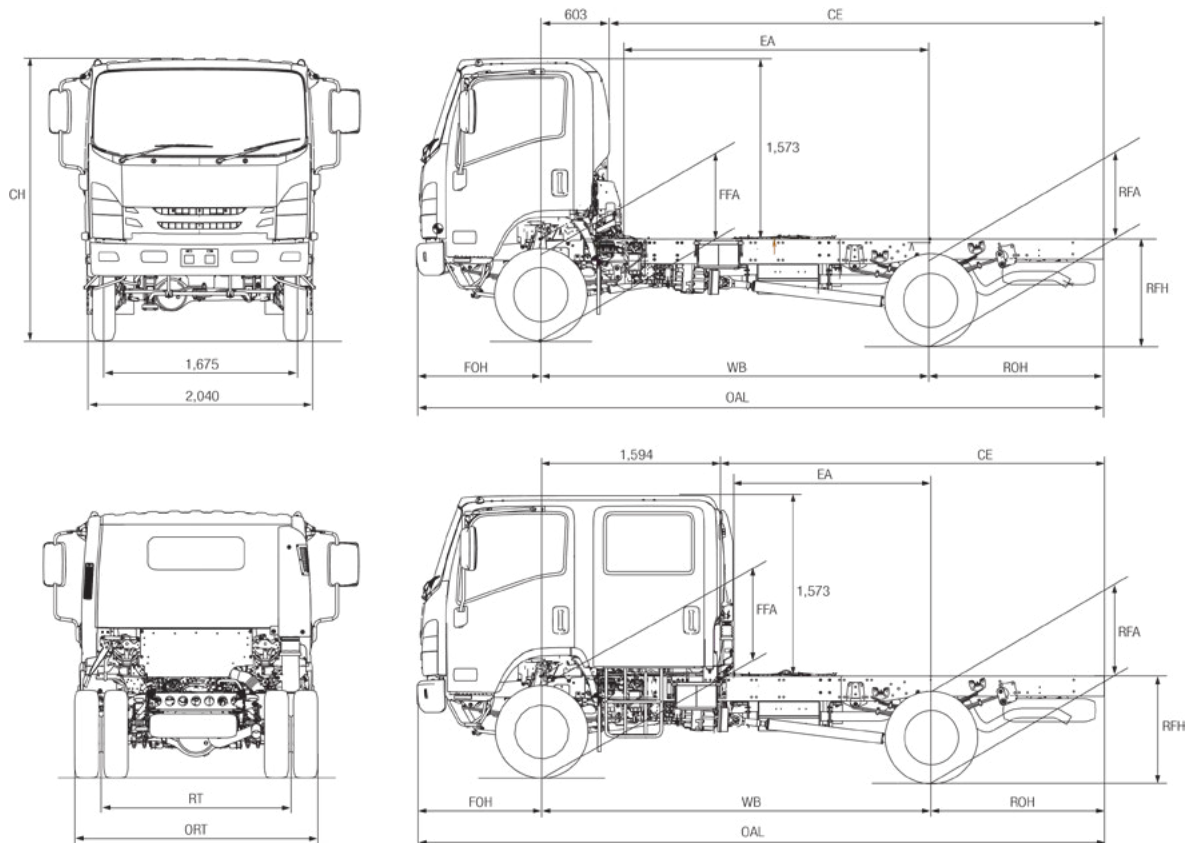

| PERFORMANCE (calculated - typical paved road) |                |   |   |                                     |
|---|----------------|---|---|-------------------------------------|
|   |                | GEARED SPEED* (top gear at peak power engine rpm) | LOW SPEED GRADEABILITY (lowest forward gear assuming no wheel slip) | ENGINE SPEED (top gear at 100 km/h) |
| NPS 45-155 4X4                                | At 4,500kg GVM | 95 km/h @ 2,600 rpm                               | > 100%  | 2,725 rpm                           |
| NPS 75-155 4X4                                | At 7,500kg GVM | 95 km/h @ 2,600 rpm                               | 62%   | 2,725 rpm                           |

\* Maximum speed achievable depends on vehicle frontal area as well as other factors. Consult your Isuzu dealer for more detailed information.

| ORDER CODES                |              |
|----------------------------|--------------|
| MODELS                     | CODES        |
| NPS 75/45-155 4X4          | NH-NPSAB-B21 |
| NPS 75/45-155 AMT 4X4      | NH-NPSAB-D21 |
| NPS 75/45-155 4X4 CREW     | NH-NPSDB-B21 |
| NPS 75/45-155 AMT 4X4 CREW | NH-NPSDB-D21 |

Subject to the conditions outlined in the IAL New Vehicle Warranty, 4x4 and AWD Isuzu N series models carry a standard factory warranty which covers the owner for the first 36 months or 150,000 kilometres (whichever comes first). All Isuzu warranties are subject to mandatory prescribed terms under Australian Consumer Law including consumer guarantees. For more details visit the Isuzu website [www.isuzu.com.au](http://www.isuzu.com.au) which explains Isuzu warranties in more detail, or alternatively contact your local Isuzu Truck dealer. All warranties commence from date of initial delivery.

ISUZU AUSTRALIA LIMITED ABN 97 006 962 572 ("IAL"). The information in this spec sheet was correct at time of printing, but all measurements, specifications and equipment are subject to change without notice. Some equipment may have been changed and/or is available at extra cost. IAL may make changes at any time without notice, in prices, colours, materials, equipment and models. IAL makes all reasonable attempts to ensure the availability of all vehicles and equipment. The information in this spec sheet is general in nature. Your Isuzu dealer can confirm all measurements, specifications and vehicle / equipment availability upon request. To the extent permitted by the law, IAL is not liable to any person as result of reliance on the content of this spec sheet.