

ISUZU

NKR 200



NKR 200 Medium pictured



ISUZU
RELIABILITY IS EVERYTHING

AT A GLANCE

GVM	4,490 kg
GCM	5,740 – 7,990 kg
Engine Type	Isuzu SiTEC 125
Displacement	3.0 L
Power	96 kW @ 3,400 rpm
Torque	280 Nm @ 1,700 rpm
Wheelbase	2,460 – 3,360 mm

Driveline and Chassis Specification

Engine SiTEC 125 (ISUZU 4JH1-TC)

Type: 4 cylinder OHV direct injection diesel. Turbocharged and air-to-air intercooled.

- Displacement:** 2,999 cc
- Compression Ratio:** 18.3:1
- Bore x Stroke:** 95.4 x 104.9 mm
- Max power (DIN-NET):** 96 kW (129 HP) @ 3,400 RPM
- Max torque (DIN-NET):** 280 Nm (207 lb.ft) @ 1,700 RPM
- Emissions Standard:** ADR 80/00 (Euro III)

Lubrication System

- External cooler. 8.0 L capacity. Full flow filter.

Cooling System

- 8 blade, 420 mm diameter cooling fan with thermostatically controlled viscous clutch.
- Radiator frontal area: 2,525 cm²
- Coolant capacity: 7.3 L

Air Intake System

- Vertical air intake mounted on back of cab. 197 x 255 mm air cleaner element.
- 420 x 220 mm air-to-air intercooler.

Fuel System

- Bosch VP44 electronically controlled distributor type fuel injection.
- Fuel/water separator with warning lamp.
- 75 L steel tank (flat low/short), 100 L steel tank (medium).

Clutch

- Auto adjusting hydraulic control.
- Single plate 300 mm diameter.
- Total lining area: 847 cm²

Transmission

Isuzu MYY-5T

- 5 Speed manual.
- Synchromesh on gears 1-5
- PTO provision on LHS of transmission case. PTO drive from counter gear.
- Gear ratios (: 1)

1st	2nd	3rd	4th	5th	Rev
5.315	3.053	1.655	1.000	0.721	5.068

Axles

Front: Isuzu Fo22

- Reverse Elliot I-beam. 2,200 kg capacity.

Rear: Isuzu Ro40

- Full floating Banjo type. Four differential pinions. 4,000 kg capacity.
- Drive ratio: 4.777:1 (Flat Low), 6.142:1 (Short/Med).

SiTEC 125
Maximum Power : 96 kW @ 3,400 RPM
Maximum Torque : 280 Nm @ 1,700 RPM

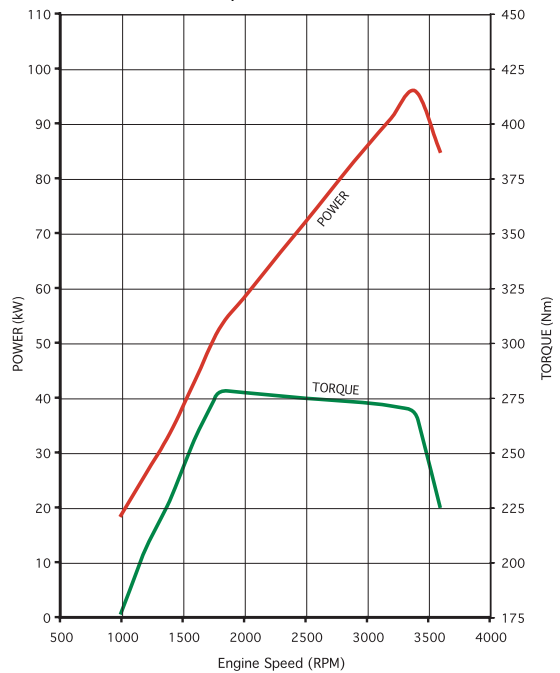

ISUZU SiTEC 125 (4JH1-TC) ENGINE PERFORMANCE CHART

Suspension

Front

- Single stage alloy steel taper-leaf springs.
- Nominal size: 1,140 x 60 mm
- Total spring capacity (at ground): 2,380 kg.
- Double acting hydraulic shock absorbers.
- Stabiliser bar (Flat Low only).

Rear

- Short/medium: Multi-leaf main spring, taper leaf helper spring. Flat low: Multi-leaf main, single leaf helper spring.
- Nominal size:

Short/Med	Flat Low
1,250 x 70 mm	1,200 x 70 mm
- Total spring capacity (at ground): 3,835 kg (Flat Low), 4,400 kg (Short/Med).
- Double acting hydraulic shock absorbers.

Brakes

- Auto-adjusting front disc and rear drum brakes, with dual circuit hydraulic control, vacuum assistance and load sensing proportioning valve.
- Standard ABS.

- | | Short/Med | Flat Low |
|---------------------------|-----------|----------|
| Front disc diameter (mm): | 293 | 293 |
| Rear drum diameter (mm): | 320 | 240 |
- 190 mm diameter drum park brake mounted on rear of transmission.
 - Vacuum controlled exhaust brake.

Steering

- Power assisted recirculating ball steering.
- Gear ratio: 22.6:1
- Turns lock to lock: 4.9

Wheels and Tyres

Short/medium

- 16 x 5.50J Five stud wheels.
- 195/85R 16 114/112L Michelin XZA Tubeless.
- Maximum tyre rating: 1,180 kg per tyre (single tyres),
1,120 kg per tyre (dual tyres).
- 1 frame mounted spare wheel and tyre assembly.

Flat low

- Front: 16 x 5.50J Five stud wheels.
195/85R 16 114/112L Michelin XZA Tubeless.
- Rear: 14 x 4.50J six stud wheels.
175R14LT 8PR Michelin XCLT Plus Tubeless.
- Front tyre rating: 1,180 kg per tyre (single tyres).
Rear tyre rating: 750 kg per tyre (dual tyres).
- 1 front, 1 rear, frame mounted spare wheel and tyre assembly supplied.

Axle Load Summary

Short/Medium

	Front	Rear
Axle Capacity (kg):	2,200	4,000
Spring Capacity (kg):	2,380	4,400
Tyre Capacity (kg):	2,360	4,480
Limit (kg):	2,200	4,000

Flat Low

	Front	Rear
Axle Capacity (kg):	2,200	4,000
Spring Capacity (kg):	2,380	3,835
Tyre Capacity (kg):	2,360	3,000
Limit (kg):	2,200	3,000

Note: Vehicle loading limit is determined by the combination of axle loading limit, GVM and GCM limit, and government regulatory requirements. Consult your Isuzu dealer to select the correct vehicle for your specific application.

Chassis Frame

- Cold riveted ladder frame. JIS-SAPH440 weldable steel.
- Frame dimensions

	Short/Med	Flat Low
Side rail (mm):	170 x 65 x 4.5	170 x 50 x 4.5
Rear frame width (mm):	700	800

Electrical System

- 12 Volt electrical system.
- 12 Volt, 80 Amp alternator.
- 12 Volt, 2.2 kW starter motor.
- 2x 80D26R (582CCA) batteries connected in parallel.

Cabin Specifications and Appointments

Cab Exterior

- All steel cab with side door impact door protection beams. Outer body panels galvanised and treated with corrosion resistant primer.
- Cab built to comply with ECE-R29 crash safety tests.
- Manual cab tilt to 45°.
- Access to fluid checkpoints without tilting cab.
- Four point tuned rubber cab mounting.
- Body coloured impact resisting polycarbonate front bumper, with steel backing frame.
- Heavy duty non slip entry steps.
- 90° opening internally reinforced doors.
- Water spray suppression guards, and front mudflaps.
- Laminated windscreen.
- Two speed windscreen wipers, with intermittent wipe mode.
- Single piece halogen multi-reflector headlamps incorporating turn signals.
- Combination brake, turn, reverse and marker lamps, registration plate illumination lamps. Extended wiring harness. Reverse alarm.
- "West Coast" type rear view mirrors. Large flat mirror glass with additional, independently adjustable convex "spot" mirror on both sides.

Cab Interior

- Wide contoured driver's bucket seat, lumbar support, reclining back, fore-aft adjustment. Two person passenger bench seat, with folding seat back. Seat tilts for access to engine.
Durable, fire resistant cloth seat facing.
- 3-point, lap sash seatbelts with emergency locking belt retractors in all outboard seating positions.
- Door and "A" pillar entry assist grips.

- Full interior trim, padded roof lining, and vinyl floor mats. Windscreen header storage shelf.
- Tilt/Telescopic adjustable steering column, soft feel urethane steering wheel.
- Electric windows.
- Central locking with remote keyless entry.
- Twin cup holders. Cigarette lighter.
- Standard fully integrated air conditioning and heater/demister with 4-speed fan and outlets for windscreen, side windows, face and floor.
- Fore-aft adjustable roof vent.
- Interior lamp with On/Door/Off switch activated by either door.
- Two speaker Eurovox radio/CD player with digital anti skip memory.
- Optional 10 stack CD player.
- DIN sized compartment below radio for storage or for CB radio installation.

Driver Controls

- Key-operated engine start/stop and steering lock.
- Left side combination stalk: Windscreen wipers, washers and exhaust brake.
- Right side combination stalk: Turn signals and headlamps.

Instrumentation

- **Gauges:** Electronically driven speedometer and tachometer. Digital odometer with integrated dual tripmeter. Engine coolant temperature and fuel level gauges.
- **Warning lamps:** Low battery charge, brake failure, low fuel level, glow plug/engine malfunction, low oil pressure, water separator.
- **Indicator lamps:** Turn signals, parking brake, high beam, exhaust brake engaged.

Performance (Calculated)

	NKR 200 Flat Low	NKR 200 Short	NKR 200 Medium
Max Geared speed:	122 km/h @ 3,600 rpm	110 km/h @ 3,600 rpm	110 km/h @ 3,600 rpm
Gradeability (lowest gear):	47% at 4,490 kg GVM	52% at 4,490 kg GVM	52% at 4,490 kg GVM
Gradeability (top gear at 100 km/h):	1.1% (2.1 x 2.3 m van body at 4,490 GVM)	3.4% (1.9 m wide tipper body at 4,490 GVM)	1.8% (2.1 x 2.3 m van body at 4,490 GVM)
Engine speed (top gear at 100 km/h):	2,955 rpm	3,280 rpm	3,280 rpm

Performance figures quoted are representative only and based on typical dimensions, body styles and weights. Please consult your Isuzu dealer for an estimation based on your specific application.

Ratings, Dimensions and Order Codes

Models	Ratings (kg)		Tare Mass* (kg)			Dimensions (mm)											Turn Circle KERB to KERB	
	GVM	GCM	TOTAL	FRONT	REAR	WB	OAL	FOH	ROH	EA	CE	RT	ORT	CH	CW	FFH UNLADEN		RFH UNLADEN
200 Short	4,490	7,990	1,935	1,280	655	2,460	4,610	1,015	1,135	1,895	3,140	1,425	1,860	2,175	1,695	645	735	11.0 m
200 Flat Low	4,490	5,740	1,820	1,275	545	2,490	4,590	1,015	1,085	1,925	3,120	1,300	1,660	2,175	1,695	645	725	11.0 m
200 Medium	4,490	7,990	2,000	1,300	700	3,360	5,830	1,015	1,455	2,795	4,360	1,425	1,860	2,175	1,695	645	735	14.2 m

TOWING CAPACITY • Unbraked trailer: 750 kg • Braked trailer: 1,250 kg (Flat Low) 3,500 kg (Short/Medium)

#Estimated mass of cab/chassis with oil, water and fuel tank containing 10 litres of fuel and including spare wheel and tools.

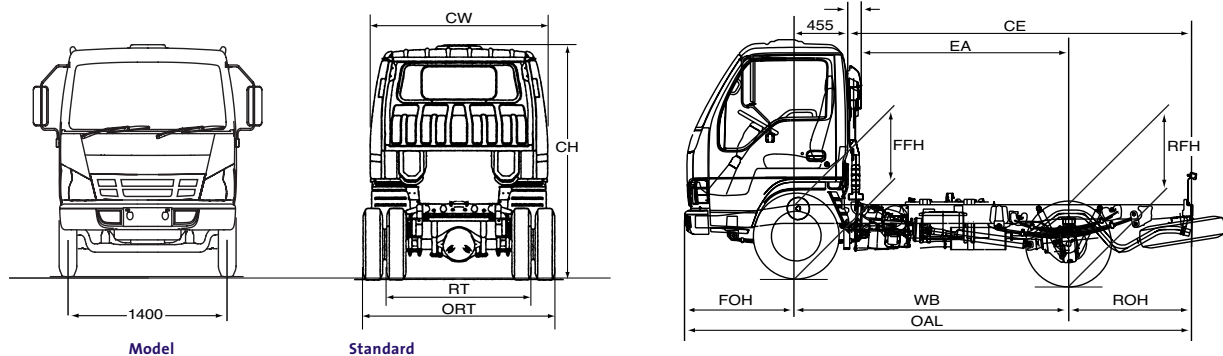

Order Codes	Model	Standard
	NKR 200 Short	8NLo2-KBS
	NKR 200 Flat Low	8NK52-KBF
NKR 200 Medium	8NLo2-KBM	

For further information regarding Cab/Chassis dimensions your Isuzu Dealer can access detailed Body Builders diagrams from the Isuzu Truck Technical Reference CD.

ISUZU New Truck Warranties

Standard Truckpower Warranty*			Truckpower Extended Warranty Options*		
New Vehicle	3 years	100,000 km	4 years 200,000 km	5 years 250,000 km	6 years 300,000 km
Drivetrain	3 years	100,000 km			
Cab Corrosion	3 years	unlimited			

* Subject to the conditions outlined in the I-GM New Vehicle Warranty, the Isuzu NKR models carry a standard factory warranty which covers the owner: (i) for the entire vehicle, for the first 36 months or 100,000 km (whichever comes first). (ii) for the drivetrain, which runs concurrently, for 36 months or 100,000 km (whichever comes first). (iii) against cab corrosion, for 36 months and unlimited kilometres.

A TruckPower Extended Warranty as illustrated is available by purchase to cover the owner against the failure of original components, but excludes some components and expendable items such as oil, filters, etc. Please consult with your Isuzu Dealer for full details obtained from a dedicated brochure available to customers.

ISUZU-GENERAL MOTORS AUSTRALIA LTD A.C.N. 006 962 572. PLEASE NOTE: as the policy of I-GM is one of continual product improvement, all specifications and equipment are subject to change without notice. No I-GM dealer or other person is authorised or permitted to give or make any statement, assertion or undertaking in relation to the quality, performance, characteristics, descriptions or fitness for any purpose of any I-GM product or in connection with the supply of any I-GM product which is at variance with any written statement, assertion or undertaking on any of these subjects given or made by I-GM in its published sales literature, and the company accepts no liability for any such unauthorised action. I-GM has franchised dealers in many parts of Australia, for the sale of service, parts and the provision of service to the owners of I-GM products. Every endeavour is made to ensure that such dealers carry adequate stocks of service parts and are equipped to provide satisfactory service, but makes no promise, other than that contained in the I-GM new vehicle warranty, that such parts or service facilities will be available or available at any specific location or at any particular time. A word about this specification sheet. We have tried to make it as comprehensive and factual as possible. However, since the time of printing some of the information you will find here may have been updated. Also, some of the equipment shown or described through this specification sheet may have been changed and/or is available at extra cost. And the right is reserved to make changes at any time without notice, in prices, colours, materials, equipment and models. Your I-GM dealer has details and before ordering, you should ask him/her to bring you up to date.

October 2005 ARK/IGM 0170

NKR 200 Short/Flat Low/Medium

ISUZU
RELIABILITY IS EVERYTHING