

ISUZU GIGA 385 CXZ



ISUZU
RELIABILITY IS EVERYTHING

AT A GLANCE

GVM	24,000 kg
GCM	50,000 kg
Engine Type	Isuzu SiTEC 385
Displacement	14.3 L
Power	287 kW @ 1,800 rpm
Torque	1,864 Nm @ 1,100 rpm
Wheelbase	4,105 mm

DRIVELINE & CHASSIS SPECIFICATIONS

ENGINE: ISUZU SiTEC 385

Isuzu 6WF1-TC 6 cylinder, 24 valve, in line, overhead camshaft, direct injection, 4-stroke, diesel.
Turbocharged and air-to-air intercooled.
Cooled exhaust gas recirculation system.
Electronic governor with integral speed limiter and cruise control with resume function.
Bore & Stroke: 147 x 140 mm
Displacement: 14,256 cc
Compression Ratio: 16.0:1
Power: 287 kW @ 1,800 rpm (ISO 1585 NET)
Torque: 1,864 Nm @ 1,100 rpm (ISO 1585 NET)
Emissions Standard: ADR80/00 (Euro III)

AIR INTAKE SYSTEM

- Donaldson dry element, 15" two stage air filter. Vertical air intake stack with slim profile side intake.

EXHAUST SYSTEM

- Vertical muffler with bright perforated heat shield on left side.
- Air controlled, butterfly type exhaust brake (up to 300 hp retardation at 2,000 rpm). Exhaust brake idle cut-out switch.

FUEL SYSTEM

- Mechanical fuel injection with Zexel Heavy Duty electronic Timing and Injection rate Control System (HD-TICS). In-line fuel filter and water sedimenter.
- Fuel tank: 1 x 400 L SAG aluminium rectangular (RHS).

LUBRICATION SYSTEM

- Pressure feed lubrication system. Oil capacity 31.0 L (including filters).

CLUTCH

EATON FULLER (SPICER) 15.5"

- Twin plate clutch (6 pads) with clutch brake.
- Asbestos free lining material.
- Pneumatic clutch release assistance.

TRANSMISSION

- Overdrive, constant mesh transmission with integral oil pump and oil cooler.

EATON FULLER RTLO 14913A (Standard transmission)

Forward Gear Ratios: (:1)

Lo: 12.31	1st: 8.64	2nd: 6.11	3rd: 4.43
4th: 3.23	5th L: 2.29	5th H: 1.95	6th L: 1.62
6th H: 1.38	7th L: 1.17	7th H: 1.00	8th L: 0.86
8th H: 0.73			

Reverse Gear Ratios: (:1)

Hi Rev H: 2.99 Hi Rev L: 3.50 Lo Reverse: 13.22

EATON FULLER 16918B (Optional transmission)

Forward Gear Ratios: (:1)

Lo L: 14.40	Lo H: 12.29	1st L: 8.56	1st H: 7.30
2nd L: 6.05	2nd H: 5.16	3rd L: 4.38	3rd H: 3.74
4th L: 3.20	4th H: 2.73	5th L: 2.29	5th H: 1.95
6th L: 1.62	6th H: 1.38	7th L: 1.17	7th H: 1.00
8th L: 0.86	8th H: 0.73		

Reverse Gear Ratios: (:1)

Hi Rev H: 2.99 Hi Rev L: 3.50 Lo Reverse: 13.22

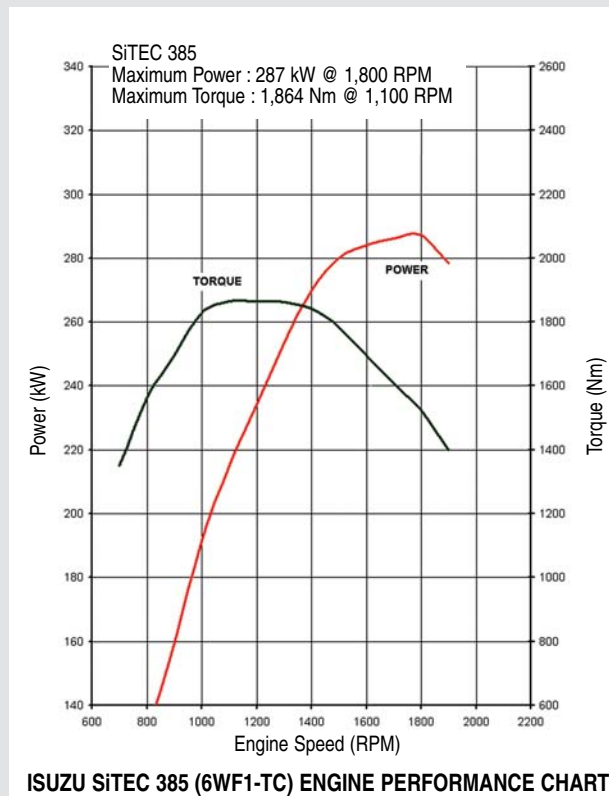

AXLES

FRONT: ISUZU F071

- 7,100 kg capacity.
- 49° wheel cut angle.

REAR: ISUZU RT210

- 21,000 kg capacity tandem axle set.
- Driver controlled inter-axle differential lock.
- Banjo type, fully floating, single reduction.
- Final drive ratio 4.333:1

SUSPENSION

FRONT

- Long span alloy steel tapered leaf springs.
- Nominal size: 1,800 x 80 mm
- Total spring capacity (at ground): 6,780 kg
- Stabiliser bar and shock absorbers.

REAR

- Isuzu 6-Rod and trunnion axle location system.
- Alloy steel taper-leaf springs.
- Total spring capacity (at ground): 23,370 kg

BRAKES

ISUZU FULL AIR "S" CAM

- Full air, S-cam dual circuit brake system with front and rear leading and trailing shoes.
- Asbestos free lining material.
- Front drum diameter: 410 mm
- Rear drum diameter: 410 mm
- Swept area: 12,880 cm²
- Air Compressor: 519 L/min at 700 kPa at 2,000 engine rpm.

- Total capacity 116.1 L, Air dryer (heavy duty desiccant type).
- Spring parking brake acting on all rear wheels.
- Trailer brake system with ball valves and “glad hand” connectors at rear of chassis.

STEERING

- Power assisted recirculating ball steering.
- Steering ratio: 22.4:1

WHEELS AND TYRES

- 8.25 x 22.5-10 stud ISO standard steel disc rims. 335 mm PCD
- 11R22.5 148/145L Michelin XDE2 (drive axle).
- 11R22.5 148/145L Michelin XZE2 (steer axle).
- Maximum tyre rating: 3,150 kg per tyre (single tyres).
2,900 kg per tyre (dual tyres).
- Spare rim only supplied on chassis (no spare tyre). Spare wheel carrier on LHS of chassis.

AXLE LOAD SUMMARY

	FRONT	REAR
Axle Capacity (kg):	7,100	21,000
Spring Capacity (kg):	6,780	23,370
Tyre Capacity (kg):	6,300	23,200
Legal Limit (kg):	6,000	16,500
Limit (kg):	6,000	16,500

Note: Vehicle loading limit is determined by the combination of axle loading limit, GVM and GCM limit, and government regulatory requirements. Consult your Isuzu dealer to select the correct vehicle for your specific application.

CHASSIS FRAME

- Ladder type, parallel rail, tapered, C-section type. HT540 steel
- Frame dimensions
Side rail (mm): 285 x 85 x 8
Rear frame width (mm): 850

ELECTRICAL SYSTEM

- 24 Volt electrical system.
- 24 Volt, 60 Amp alternator(1.5 kW).
- 24 Volt, 7.4 kW starter motor.
- 2 x 145G51(754CCA) batteries connected in series.

GENERAL OPTIONS (available at extra cost)

- Additional 400 L Hilton aluminium fuel tank (deletes spare wheel carrier).
- High Torque Permanent Magnet type Retarder. NT65 Heavy Duty type, mounted ahead of rear axles, provides up to 640 Nm of retardation torque on the driveline. Reduces service brake wear, driver fatigue and tyre wear. Retarder only available on 18 speed CXZ.
- Eaton Fuller RTLO16918B 18 speed overdrive transmission.

DEALER-FITTED ACCESSORIES INCLUDE:

- Voltage reducer (24 Volt-12 Volt) for 12 Volt trailer electrics.
- Roof Mounted Air Deflector. Designed by Isuzu for use with tall body designs, reducing fuel consumption.

CABIN SPECIFICATIONS AND APPOINTMENTS

CAB EXTERIOR

- All steel cab with welded ribs and side door impact beams. Standard colour: Arc White.
- Hydraulic/electric cabin tilt to 48°. Lift-up front panel for easy access to service items. Air suspended cab with four electronically controlled pneumatic mounts, shock absorbers and torque tube.
- Body coloured steel front bumper with step holes.
- Halogen headlights in bumper with hinges for easy cleaning. Integrated indicator and fog lamps.
- Three arm windscreen wipers with triple washer jets mounted on washer arms.
- Main external rear view mirrors with integrated convex ‘spotter’ mirror on both sides. Electric remote adjustment and heating elements in all four external mirrors.
- Integrated front corner vanes for improved airflow.
- Fully enclosed alloy, non-slip cab entry steps.

CAB INTERIOR

- Fully trimmed cab interior with cloth seat facings, formed roof lining and overhead storage lockers. Sun visors on both sides.
- 24 Volt & 12 Volt cigarette lighter/electrical accessory socket.
- Isringhausen 6800 driver’s air suspended seat with integrated seat belt, pneumatic lumbar support, automatic weight adjustment and dump button for ease of entry and exit. Height, rake and backrest recline adjustment.
- Outboard non-suspended reclining co-driver’s seat with matching Isringhausen trim.
- Folding centre seat with lap type seatbelt, storage console on seat back. Twin cup holders in centre console.
- Easy entry grab handles on ‘A’ and ‘B’ pillars.
- Fluorescent overhead interior lamp.
- Integrated air conditioning is standard.
- Electric windows. Central locking with remote keyless entry.
- Radio/CD player with clock, front and rear speakers.
- Hard wearing vinyl floor covering.
- ADR compliant sleeper mattress: approx. 2,200 x 600 x 100 mm thick. Centre curtain for privacy when sleeping.
- Secure storage trunk with external access on LHS.

GIGA 385 CXZ

PERFORMANCE (Calculated)

385 CXZ	
Max Geared speed:	117* km/h @ 1,900 rpm
Gradeability (lowest gear):	41% at 42,500 kg GCM
Gradeability (top gear at 100 km/h):	0.9% (Tipper and dog trailer at 42,500 kg CGM)
Engine speed (top gear at 100 km/h):	1,620 rpm

Performance figures quoted are representative only and based on typical dimensions, body styles and weights. Please consult your Isuzu dealer for an estimation based on your specific application. * Road speed limited to 100 km/h

MODEL RATINGS AND DIMENSIONS

MODELS	RATINGS (kg)		TARE MASS [#] (kg)			DIMENSIONS (mm)													TURN CIRCLE KERB TO KERB
	GVM	GCM	TOTAL	FRONT	REAR	WB	OAL	FOH	ROH	EA	CE	RT	ORT	CH	CW	FFH UNLADEN	RFH UNLADEN		
CXZ	24,000	50,000	7,790	4,245	3,545	4,105	7,485	1,400	1,980	2,920	5,430	1,855	2,465	2,970	2,490	900	1,095	13.8 m	

#Estimated mass of cab/chassis with oil, water and fuel tank containing 20 litres of fuel.

Option Masses: • Roof Mounted Air Deflector add 35 kg • Side fairings add 60 kg • Additional fuel tank add 90 kg

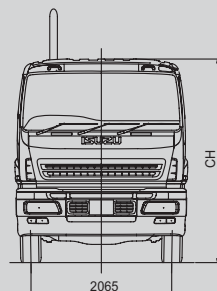
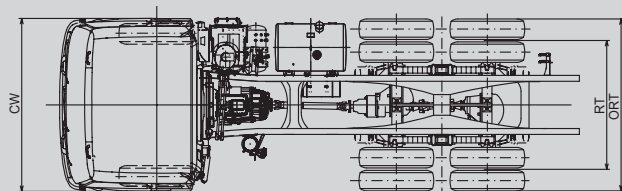

For further information regarding Cab/Chassis dimensions your Isuzu Dealer can access detailed Body Builders diagrams from the Isuzu Truck Technical Reference CD.

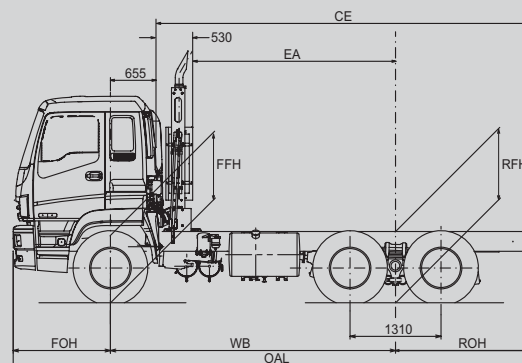

Model 13spd 18spd 18spd + retarder

ORDER CODES 385 CXZ 8CZ22-314 (MU2) 8CZ22-414 (MU2) 8CZ22-424 (MU2)

ISUZU NEW TRUCK WARRANTIES

STANDARD TRUCKPOWER WARRANTY*

New Vehicle	3 years	500,000 km
Engine Components**	5 years	750,000 km
Cab Corrosion	3 years	unlimited

* Subject to the conditions outlined of the IAL New Vehicle Warranty, every Isuzu Giga Series Truck carries a warranty which covers your complete vehicle for the first 36 months or 500,000 km (whichever comes first). Normal exclusions apply: e.g. tyres and batteries (refer to your Isuzu Dealer for details).

A 60 month or 750,000 km (whichever comes first) major engine components warranty runs concurrently with the New Vehicle Warranty for Giga Series models. A 36 month unlimited km cab perforation corrosion warranty runs on all models.

** Engine components are as follows: Cylinder block, cylinder head and crankshaft.

ISUZU AUSTRALIA LIMITED A.C.N. 006 962 572. PLEASE NOTE: as the policy of IAL is one of continual product improvement, all specifications and equipment are subject to change without notice. No IAL dealer or other person is authorised or permitted to give or make any statement, assertion or undertaking in relation to the quality, performance, characteristics, descriptions or fitness for any purpose of any IAL product or in connection with the supply of any IAL product which is at variance with any written statement, assertion or undertaking on any of these subjects given or made by IAL in its published sales literature, and the company accepts no liability for any such unauthorised action. IAL has franchised dealers in many parts of Australia, for the sale of service, parts and the provision of service to the owners of IAL products. Every endeavour is made to ensure that such dealers carry adequate stocks of service parts and are equipped to provide satisfactory service, but makes no promise, other than that contained in the IAL new vehicle warranty, that such parts or service facilities will be available or available at any specific location or at any particular time. A word about this specification sheet. We have tried to make it as comprehensive and factual as possible. However, since the time of printing some of the information you will find here may have been updated. Also, some of the equipment shown or described through this specification sheet may have been changed and/or is available at extra cost. And the right is reserved to make changes at any time without notice, in prices, colours, materials, equipment and models. Your IAL dealer has details and before ordering, you should ask him/her to bring you up to date.

MARCH 2007. ARK 0241

ISUZU

RELIABILITY IS EVERYTHING